

Esquema de Montagem

Balcão Alto Kaya

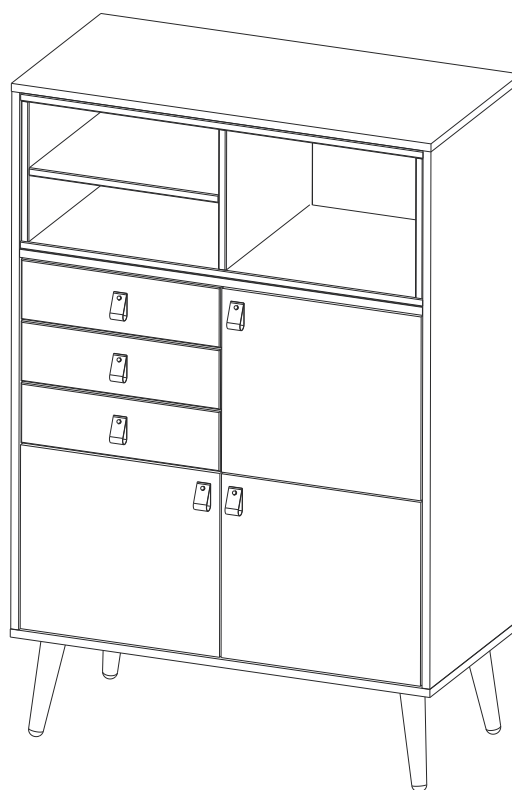

ferramentas necessárias
(não fornecidas)









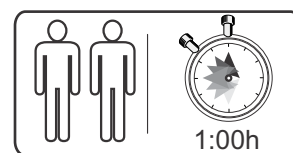



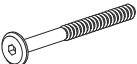
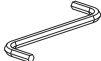







chave phillips

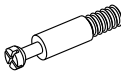
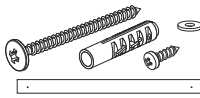

martelo de borracha

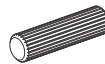

Ferragens

A		7 x 50	04	L		Chave Allen	01
B		4,0 x 40	03	M		Rv8	22
C		4,0 x 30	12	N		Corrediça 350mm	03
D		5/32 x 5/8	06	O		Puxador	06
E		4,0 x 16	24	P		Suporte Prateleira	08
F		3,5 x 14	24	Q		Dobradiça	06
G		3,0 x 16	22	R		Tapa Furo	04
H		Rapid Minifix	38	S		Kit Antitombamento	01
I		Tambor Minifix	42	T		Prego	05
J		Haste Dupla Minifix	02	U		Chapa União	05
K		Ø8x30	34	V		Ø6x30	04

Componentes

N.	Componentes	Quant.
01	Tampo	01
02	Fundo	01
03	Lateral Esquerda	01
04	Lateral Direita	01
05	Tampo Intermediário	01
06	Divisão Inferior	01
07	Divisão Superior	01
08	Prateleira	01
09	Traseira	02
10	Prateleira Nicho	01
11	Porta Esquerda	01
12	Porta Direita	02
13	Frente Gaveta	03
14	Lateral Direita Gaveta	03
15	Lateral Esquerda Gaveta	03
16	Traseira Gaveta	03
17	Fundo de Gaveta	03
18	Pé Torneado	04
19	Travessa Reforço	01
20	Prateleira Móvel	02
21	Tampo Nicho	02
22	Lateral Esquerda Nicho	01
23	Lateral Direita Nicho	01
24	Divisão Nicho	01

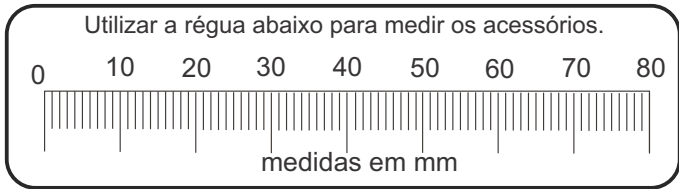
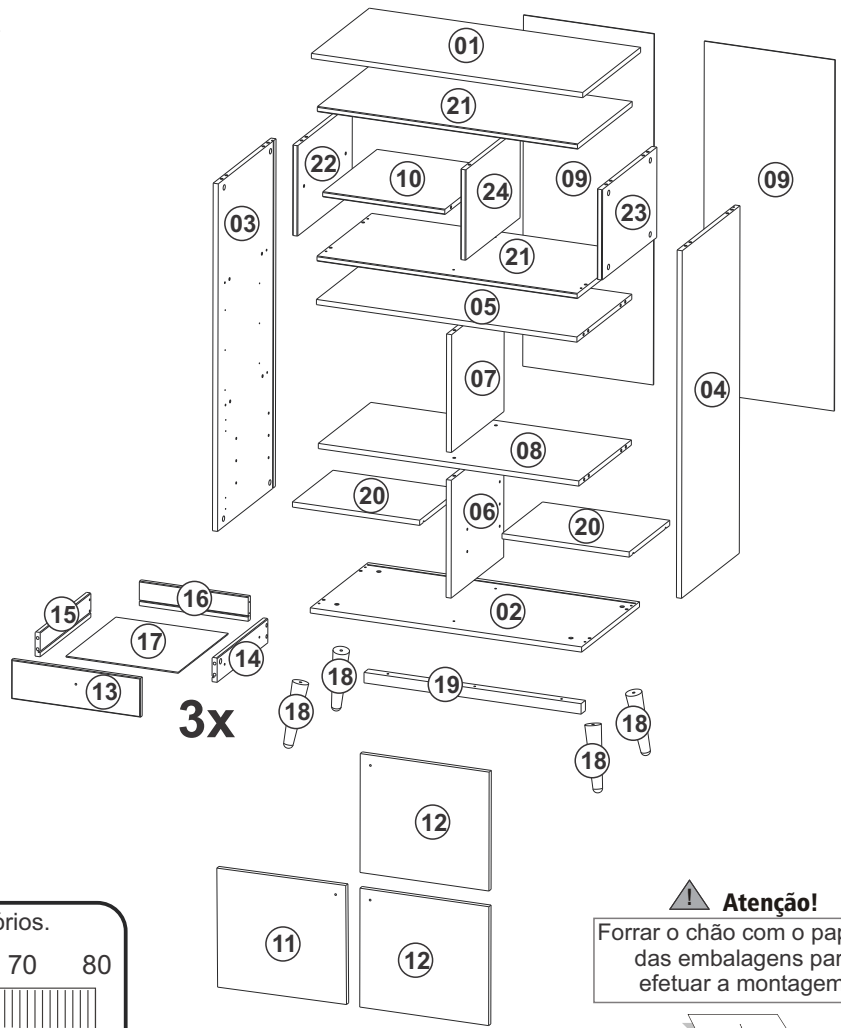

Atenção!
Forrar o chão com o papelão das embalagens para efetuar a montagem.

Passo 01

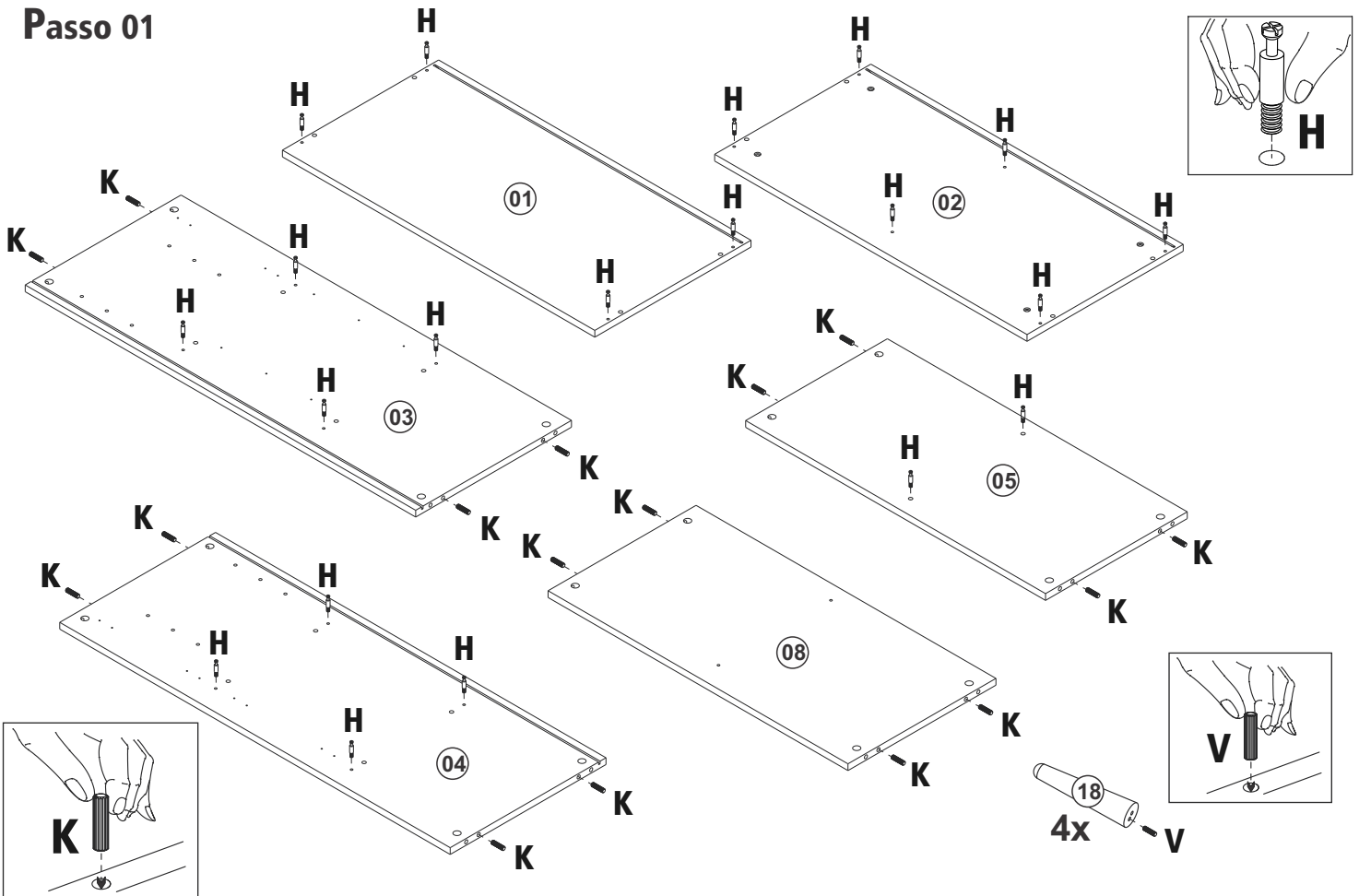

Passo 02

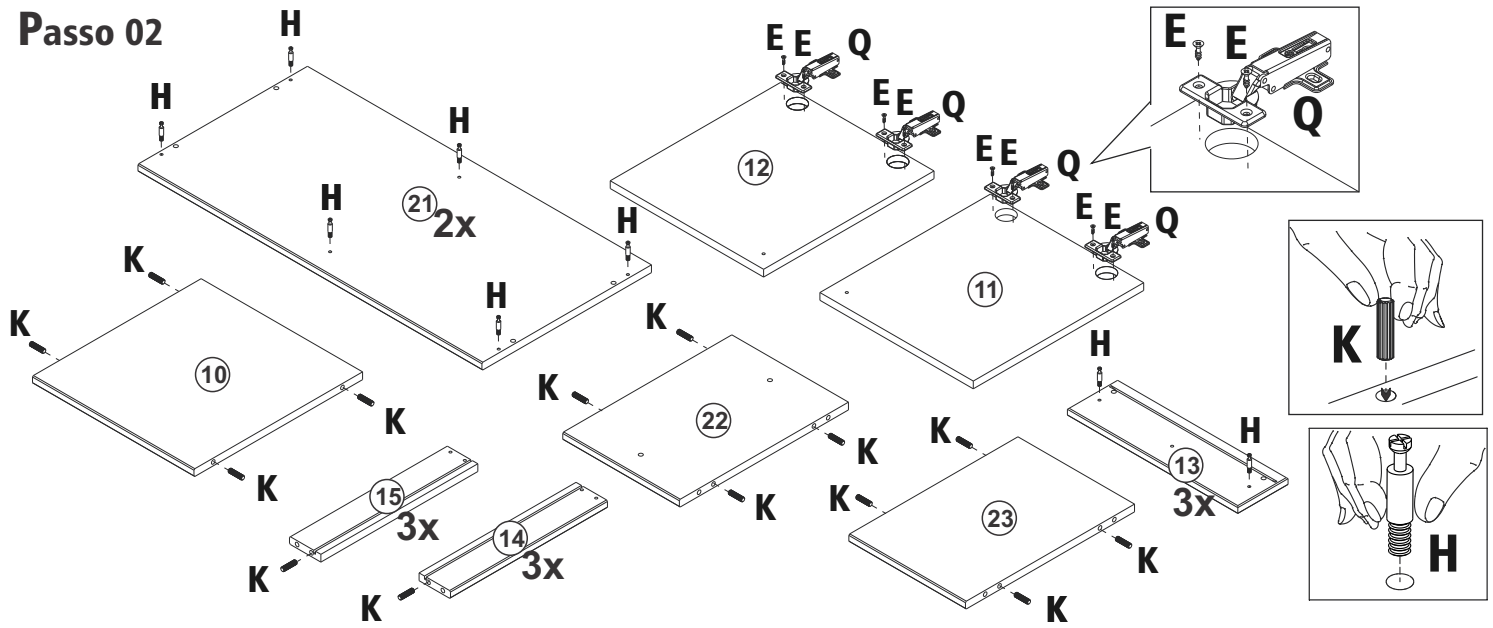

Passo 03

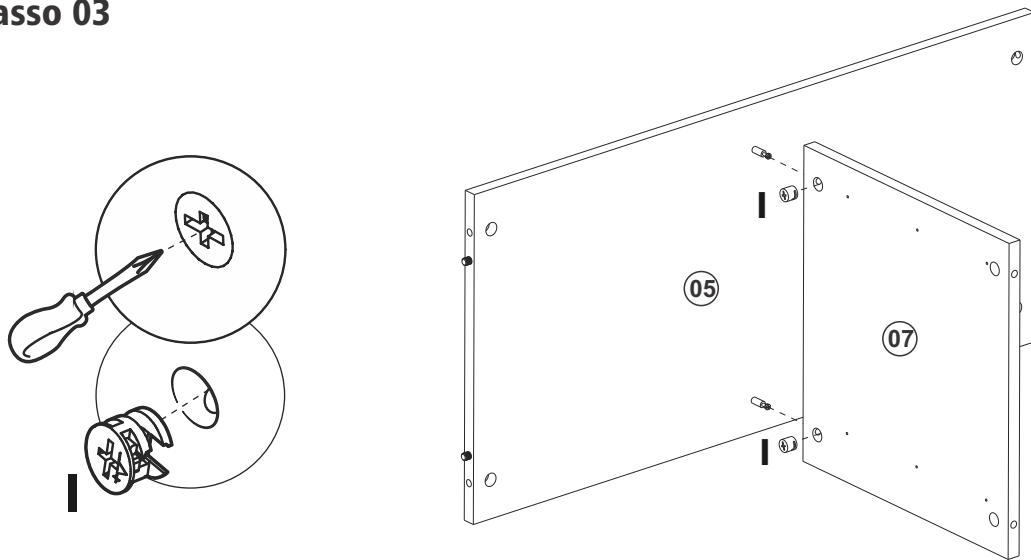

Passo 04

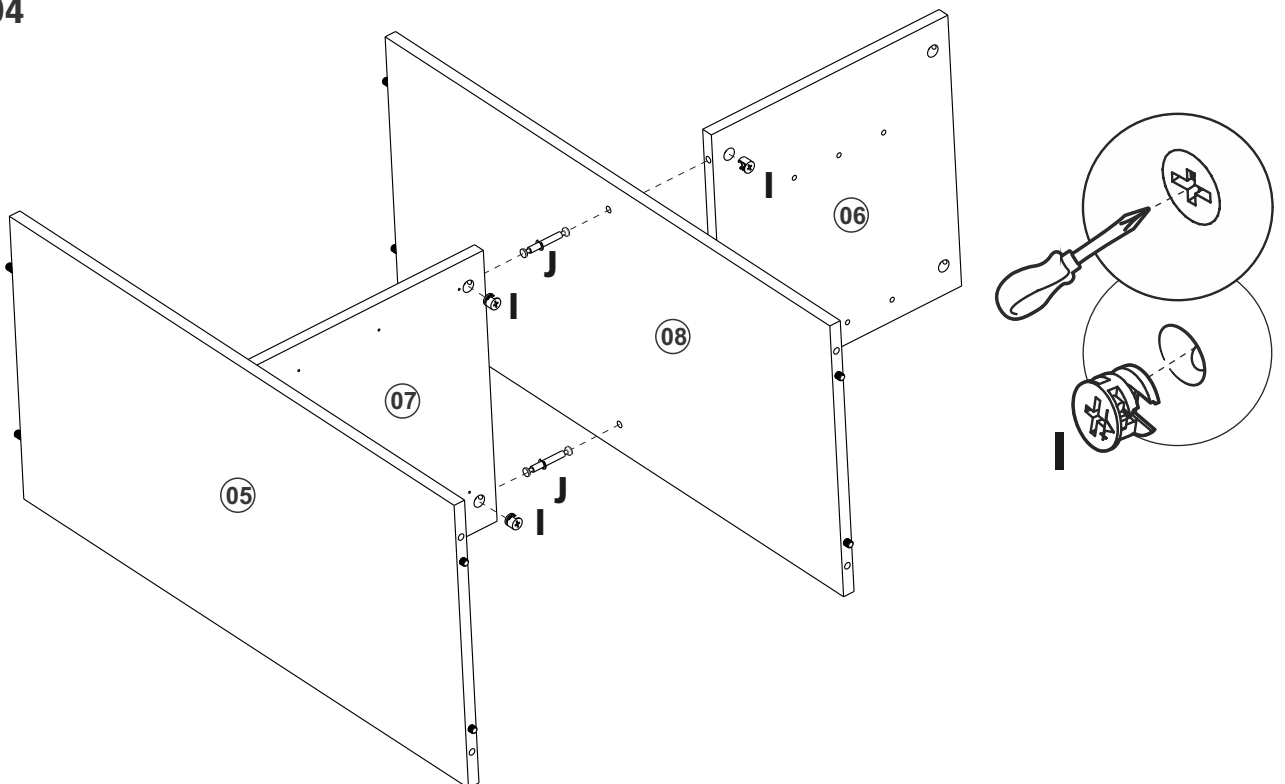

Passo 05

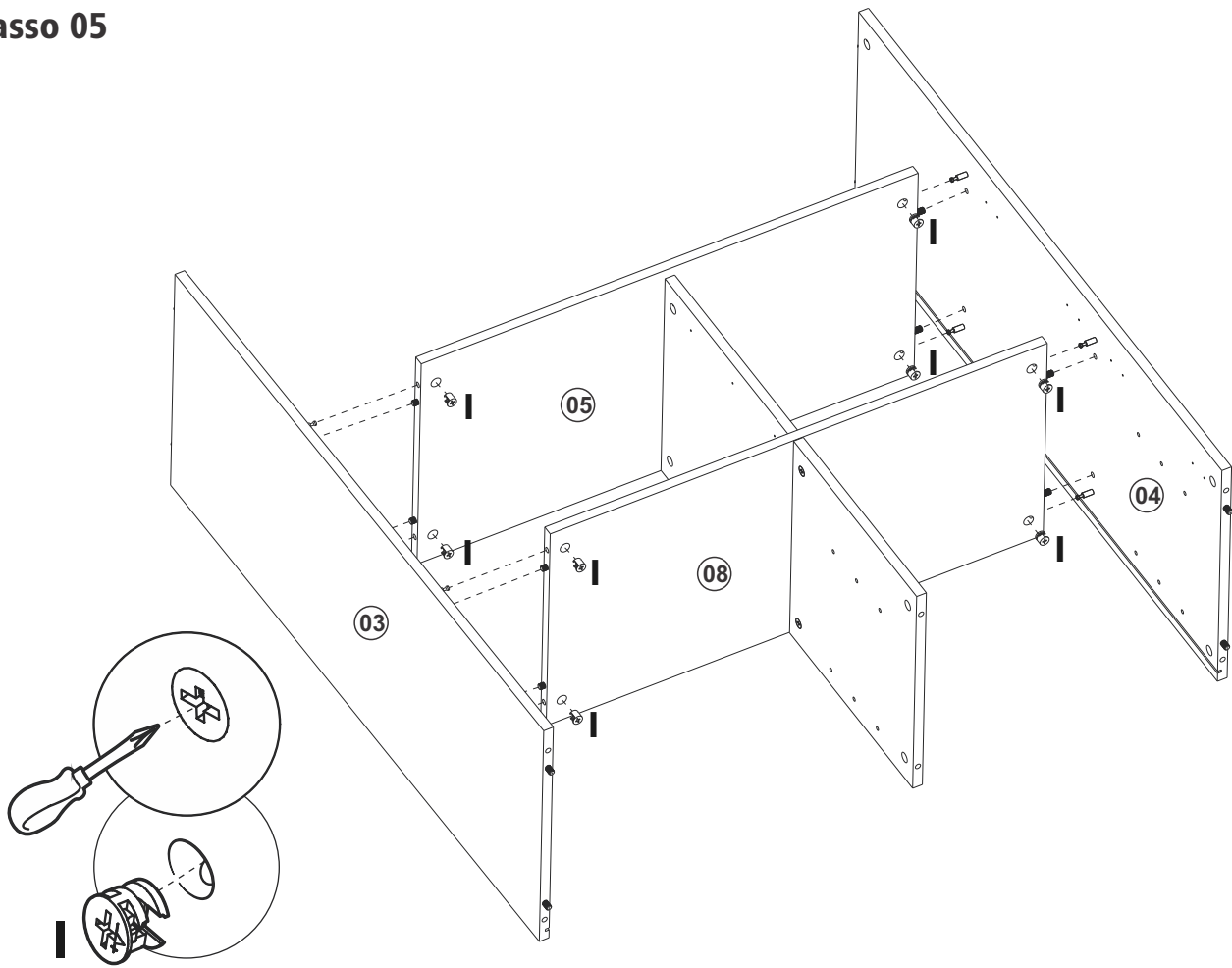

Passo 06

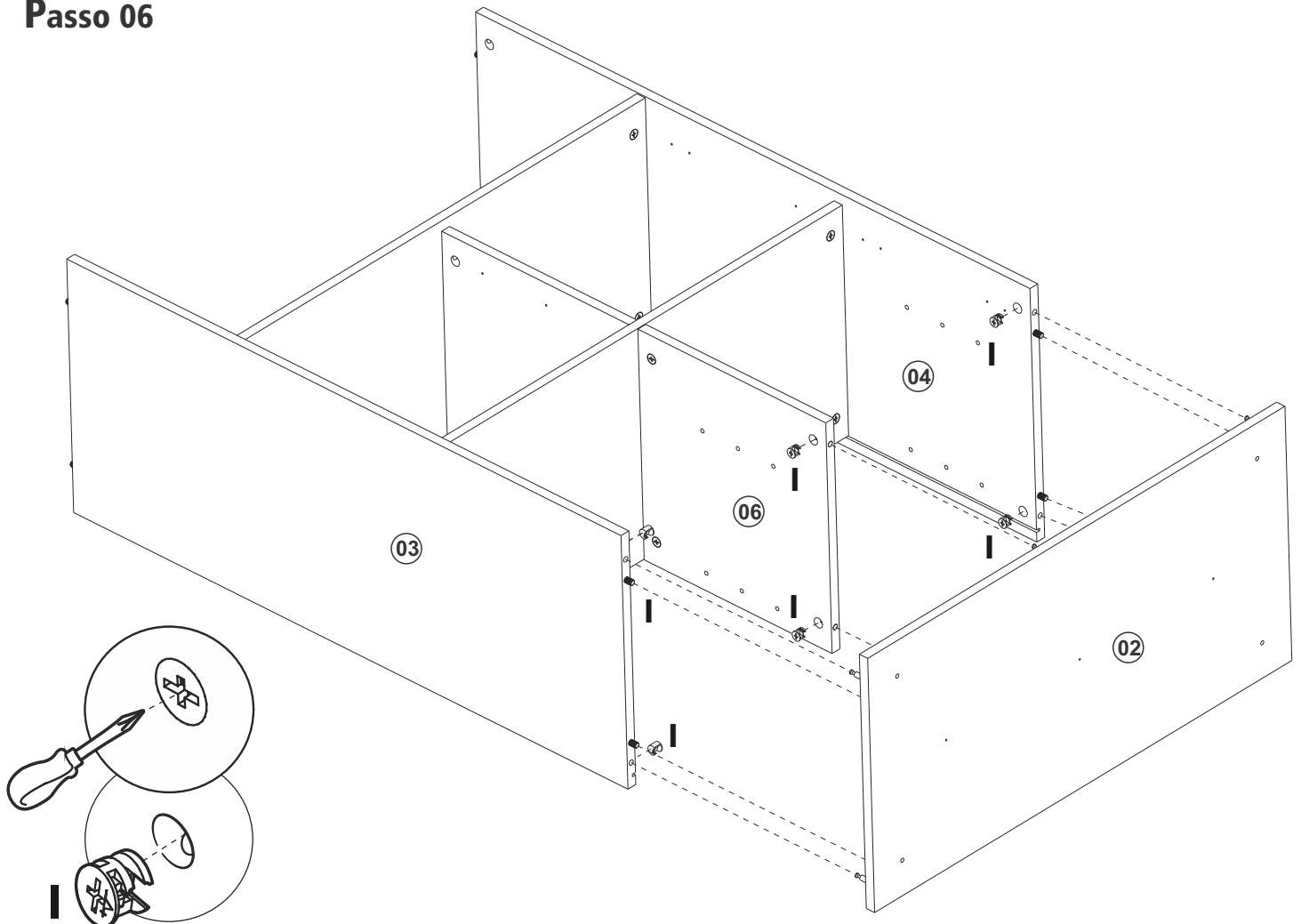

Passo 07

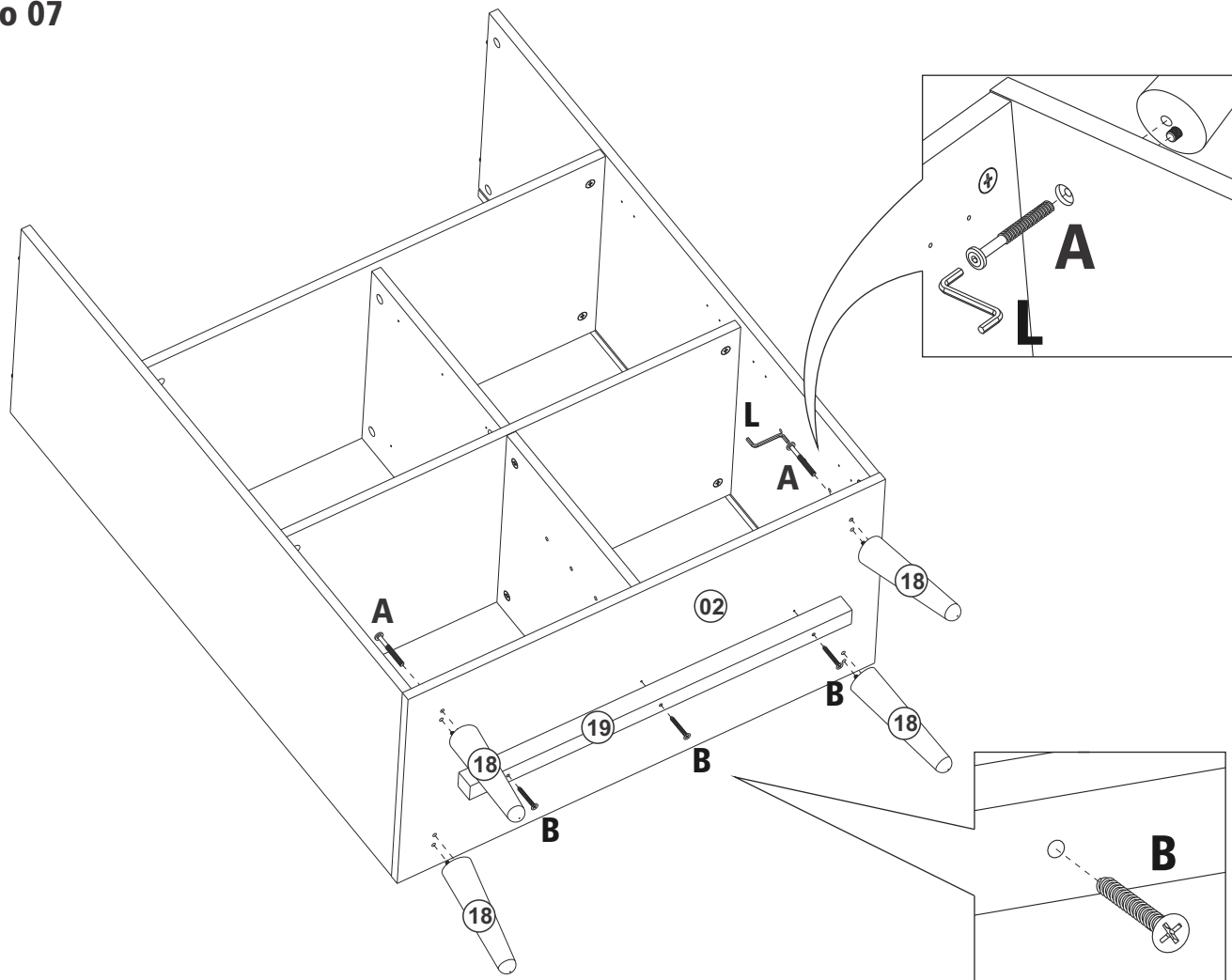

Passo 08

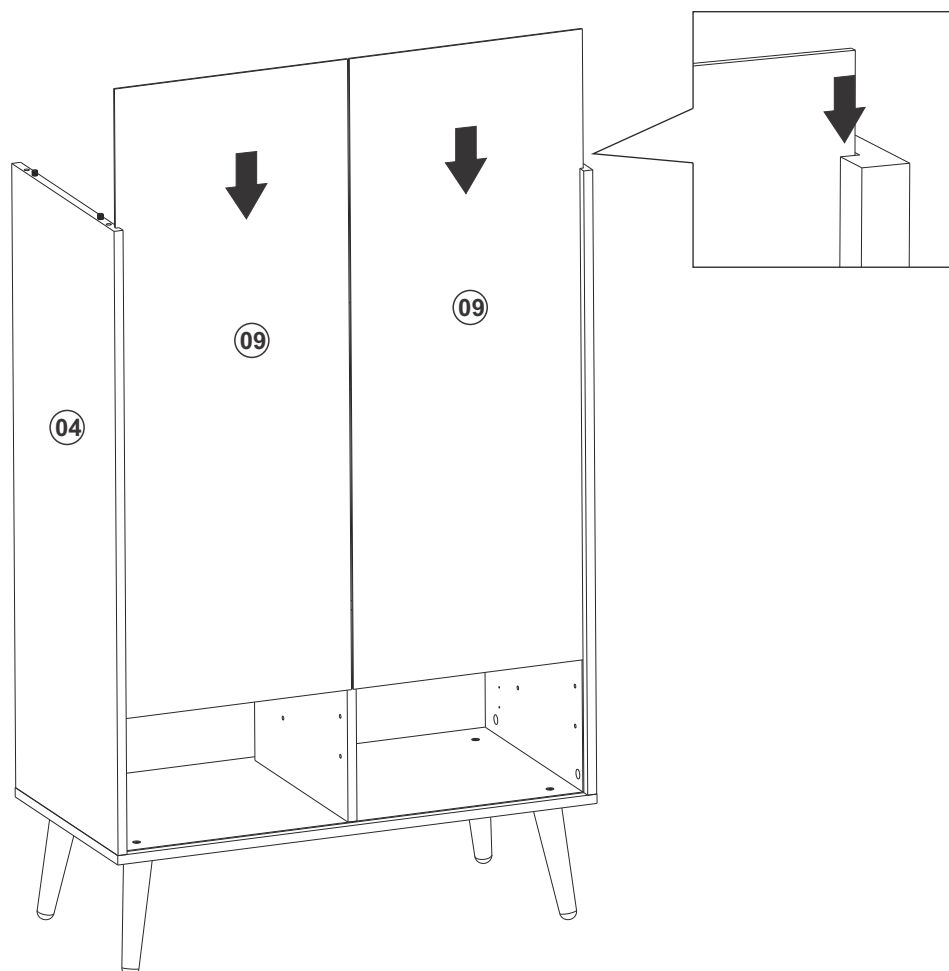

Passo 09

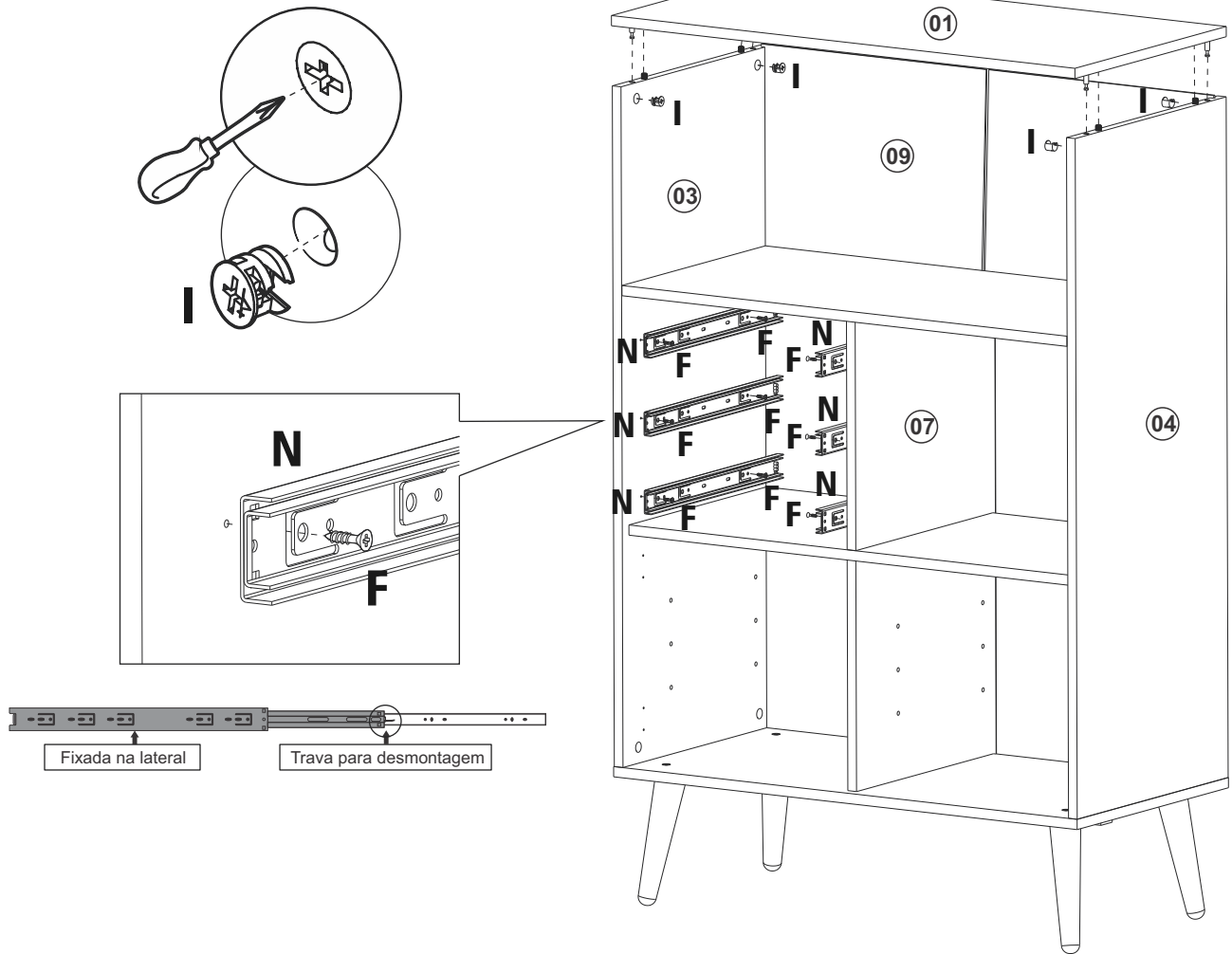

Passo 10

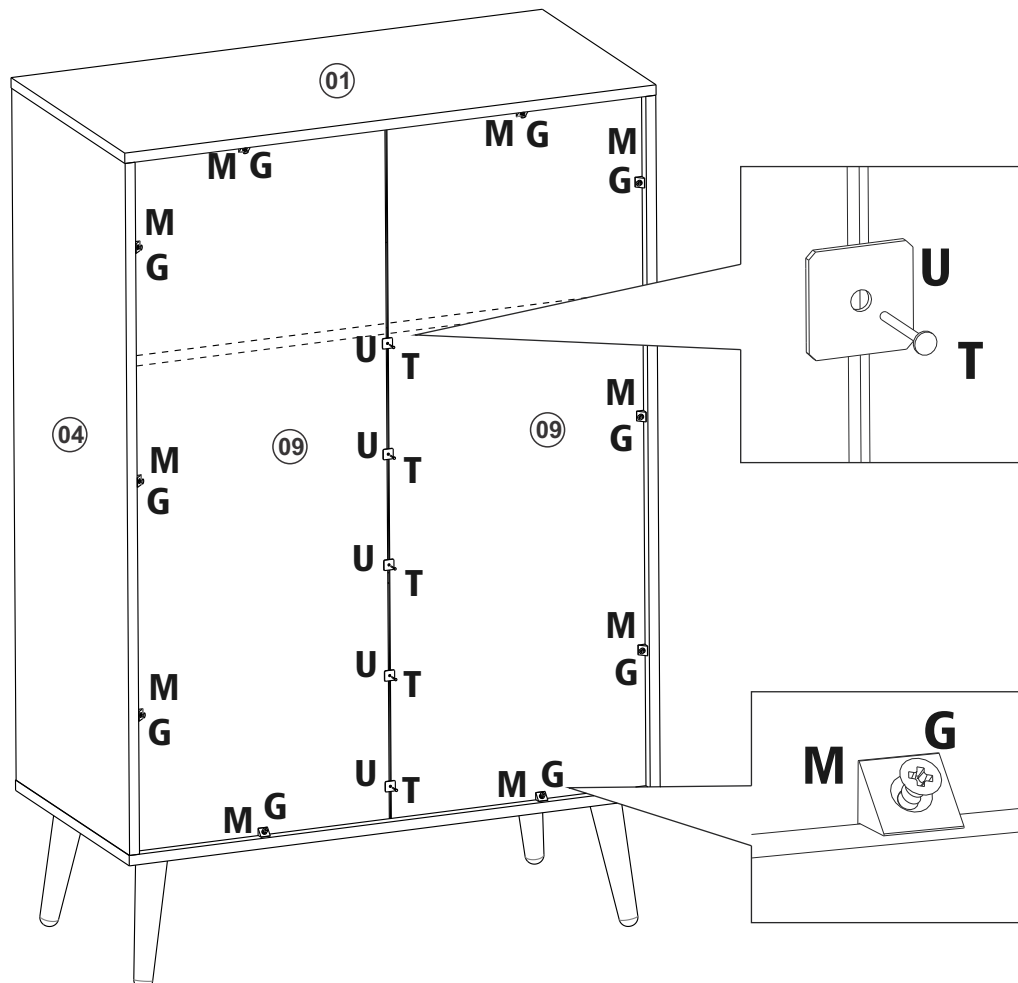

Passo 11

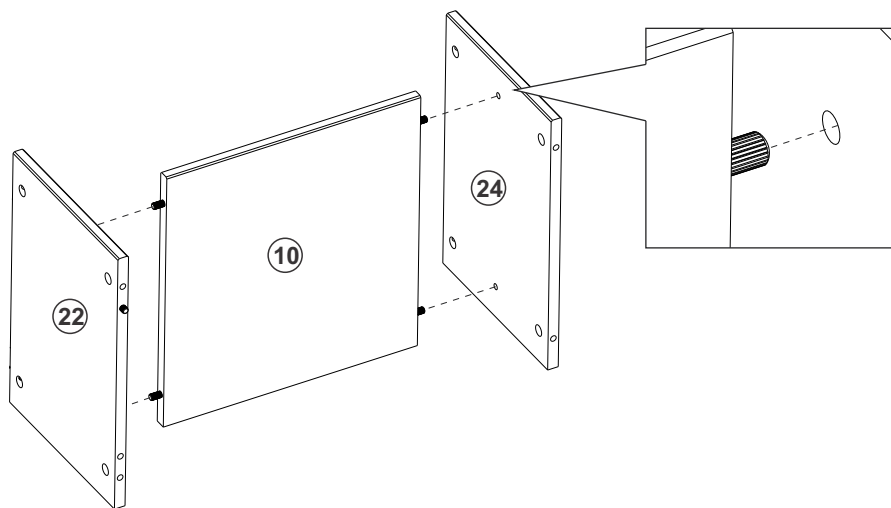

Passo 12

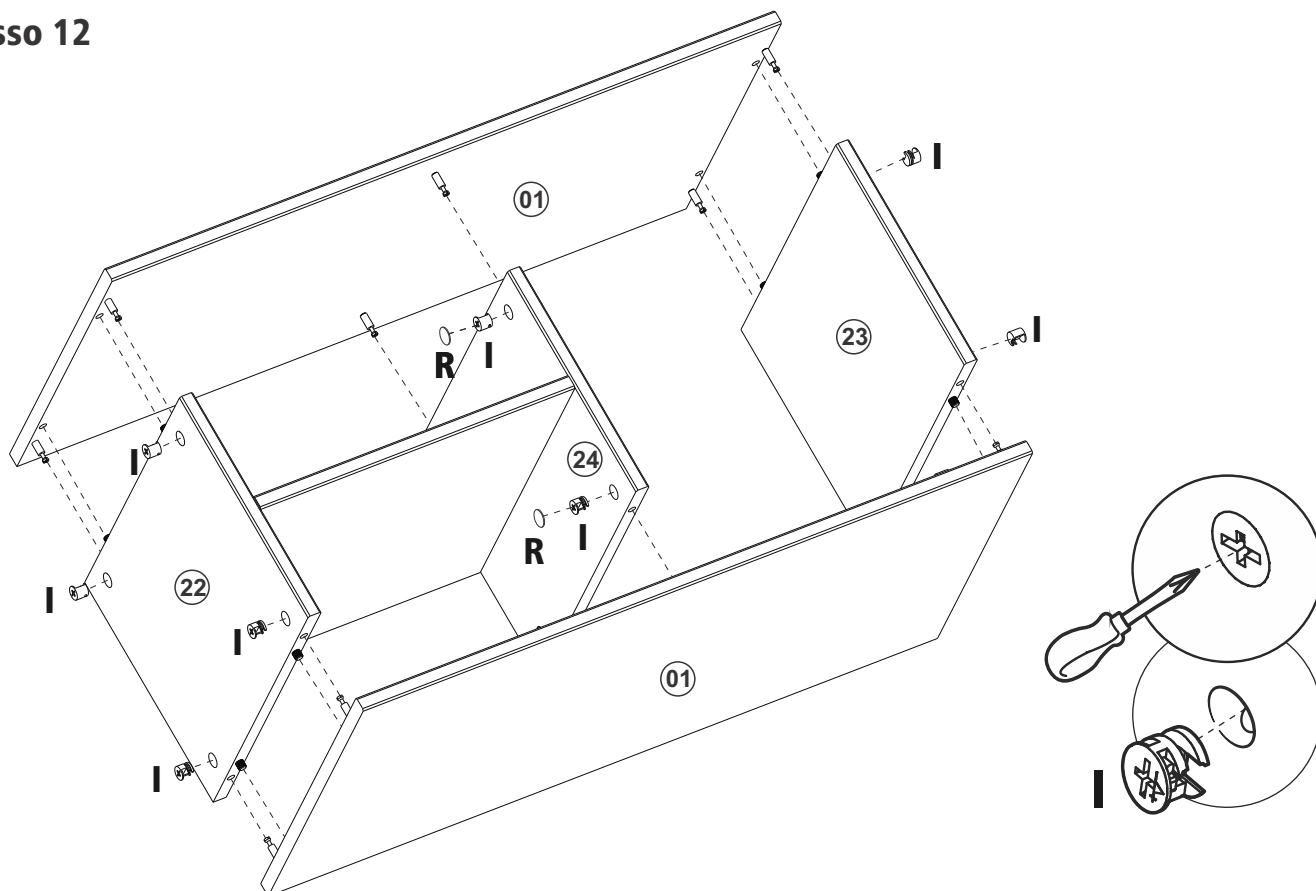

Passo 13

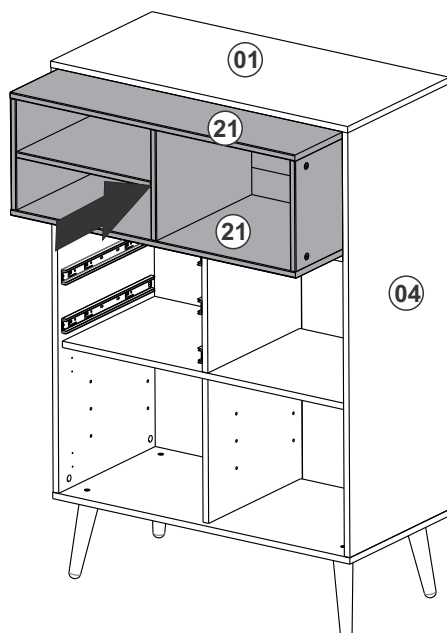

Passo 14

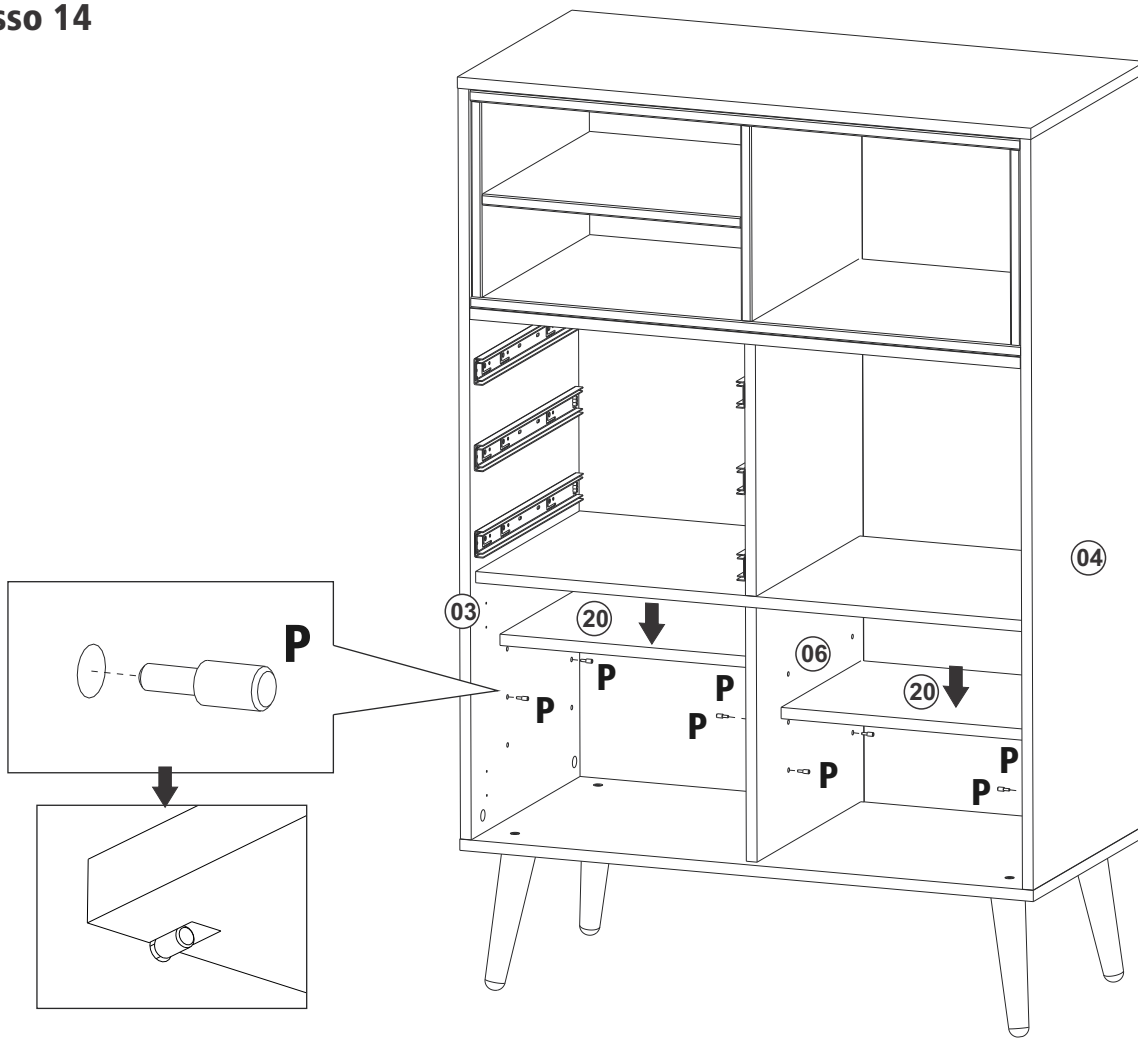

Passo 15 3x

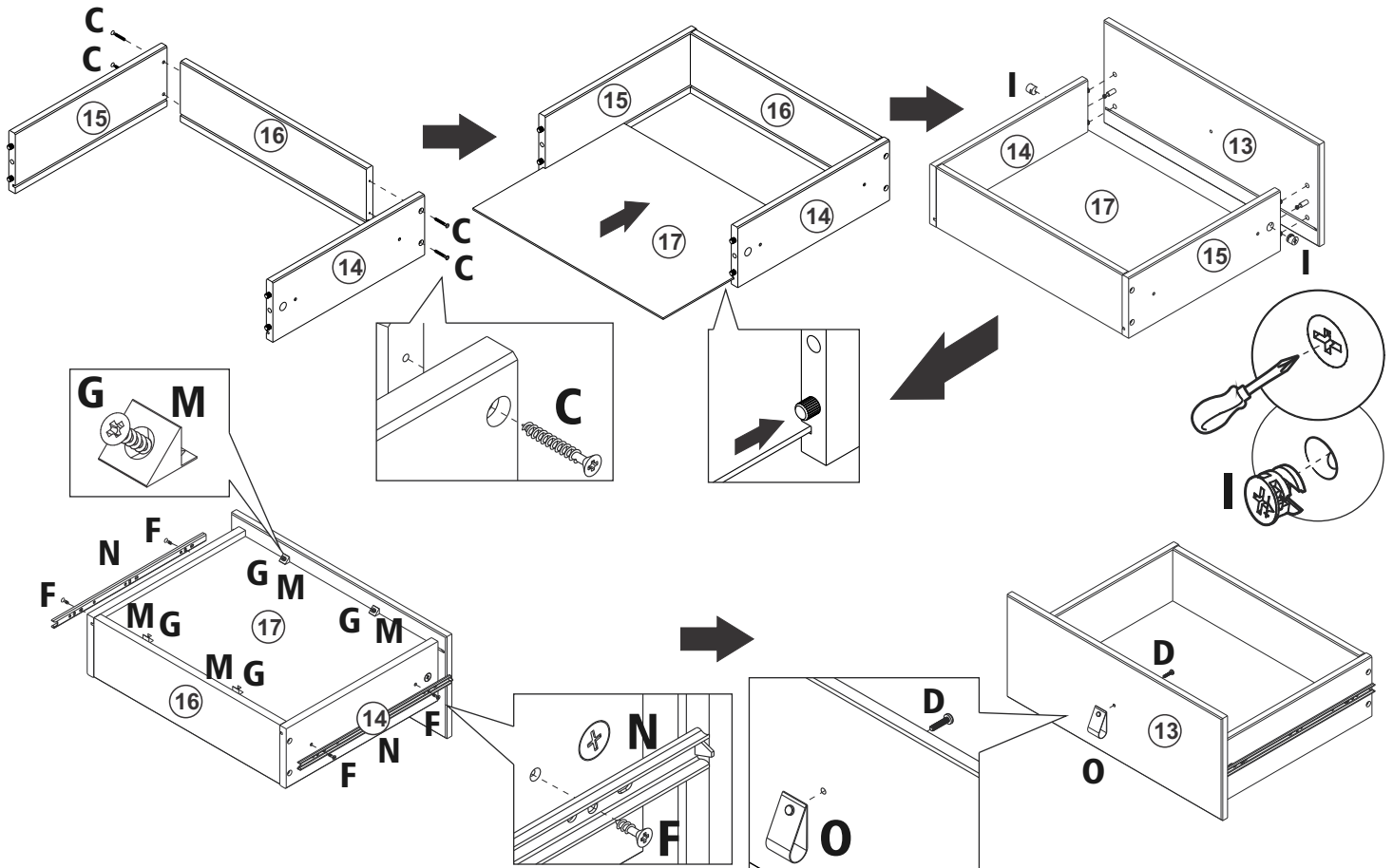

Passo 16

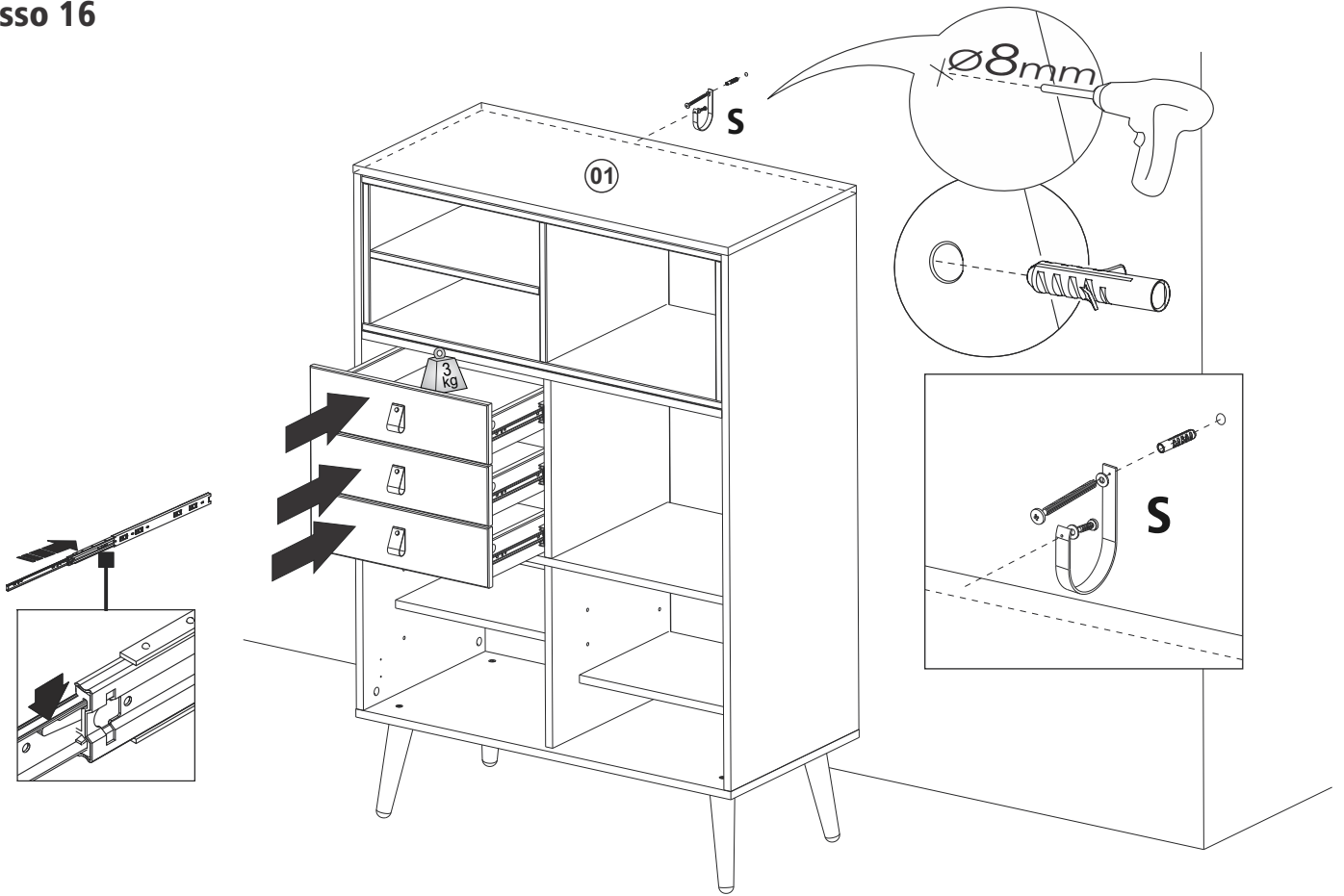

Passo 17

