

Esquema de Montagem Cristaleira Kaya

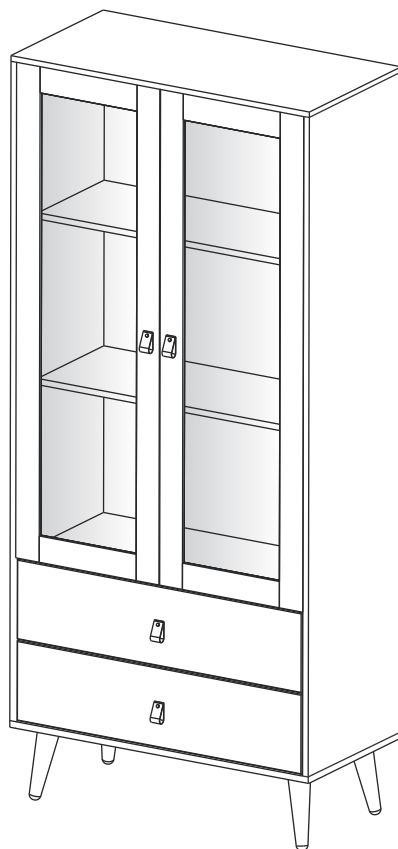

ferramentas necessárias
(não fornecidas)









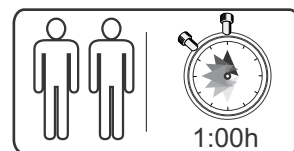



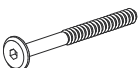





chave phillips



martelo de borracha

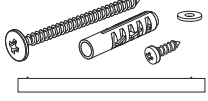
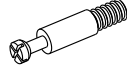
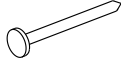

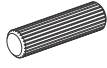
Ferragens

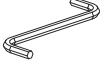
A		7 x 50	04	L		Rv8	30
B		4,0 x 40	03	M		Corrediça 350mm	02
C		4,0 x 30	08	N		Puxador	04
D		5/32 x 5/8 e Bucha	04	O		Batente	02
E		4,0 x 16	24	P		Dobradiça	06
F		3,5 x 14	18	Q		Tapa Furo	12
G		3,0 x 16	30	R		Kit Antitombamento	01
H		Rapid Minifix	24	S		Prego	12
I		Tambor Minifix	24	T		Chapa União	12
J		Ø8x30	28	U		Ø6x30	04
K		Chave Allen	01				

Componentes

N.	Componentes	Quant.
01	Tampo	01
02	Fundo	01
03	Lateral Direita	01
04	Lateral Esquerda	01
05	Tampo Intermediário	01
06	Pé Torneado	04
07	Travessa Reforço	01
08	Prateleira	02
09	Traseira	04
10	Porta com Vidro	02
11	Frente Gaveta	02
12	Lateral Direita Gaveta	02
13	Lateral Esquerda Gaveta	02
14	Traseira Gaveta	02
15	Fundo de Gaveta	02

⚠ Atenção!

Forrar o chão com o papelão das embalagens para efetuar a montagem.

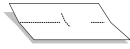

Utilizar a régua abaixo para medir os acessórios.

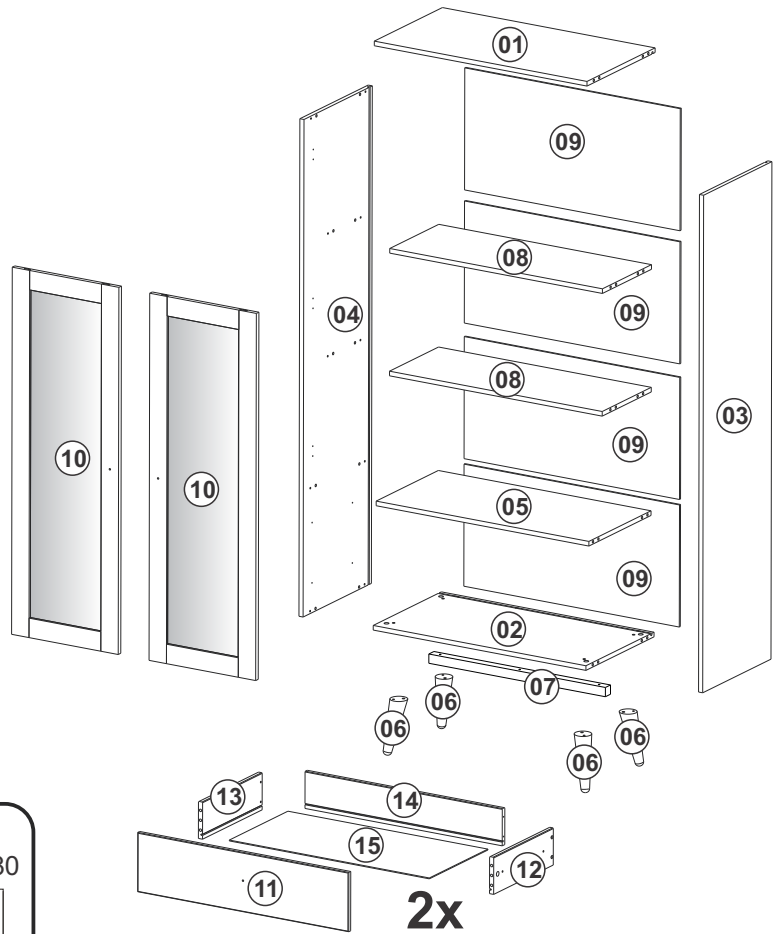
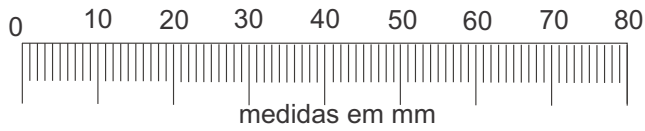

Passo 01

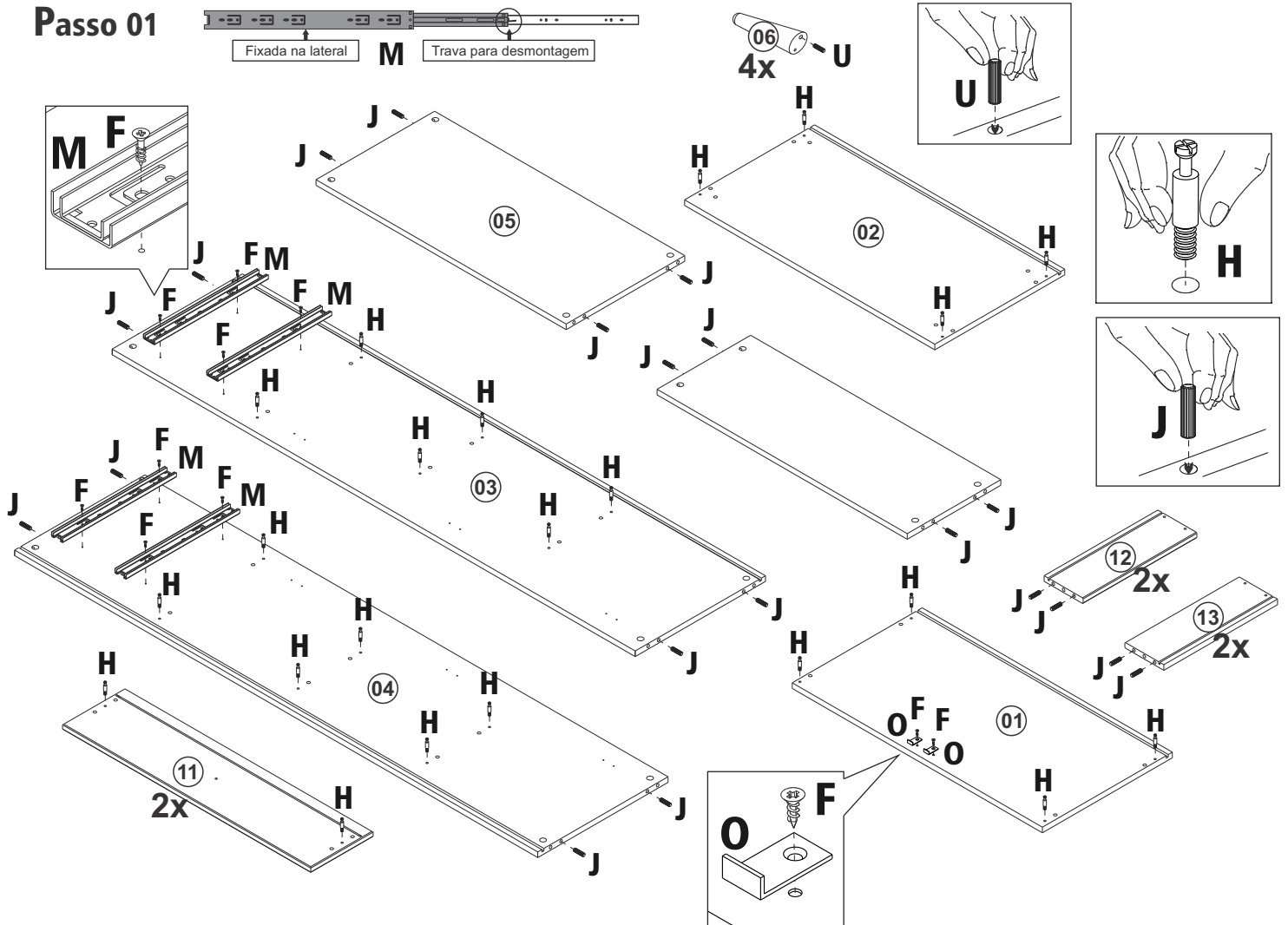

Passo 02

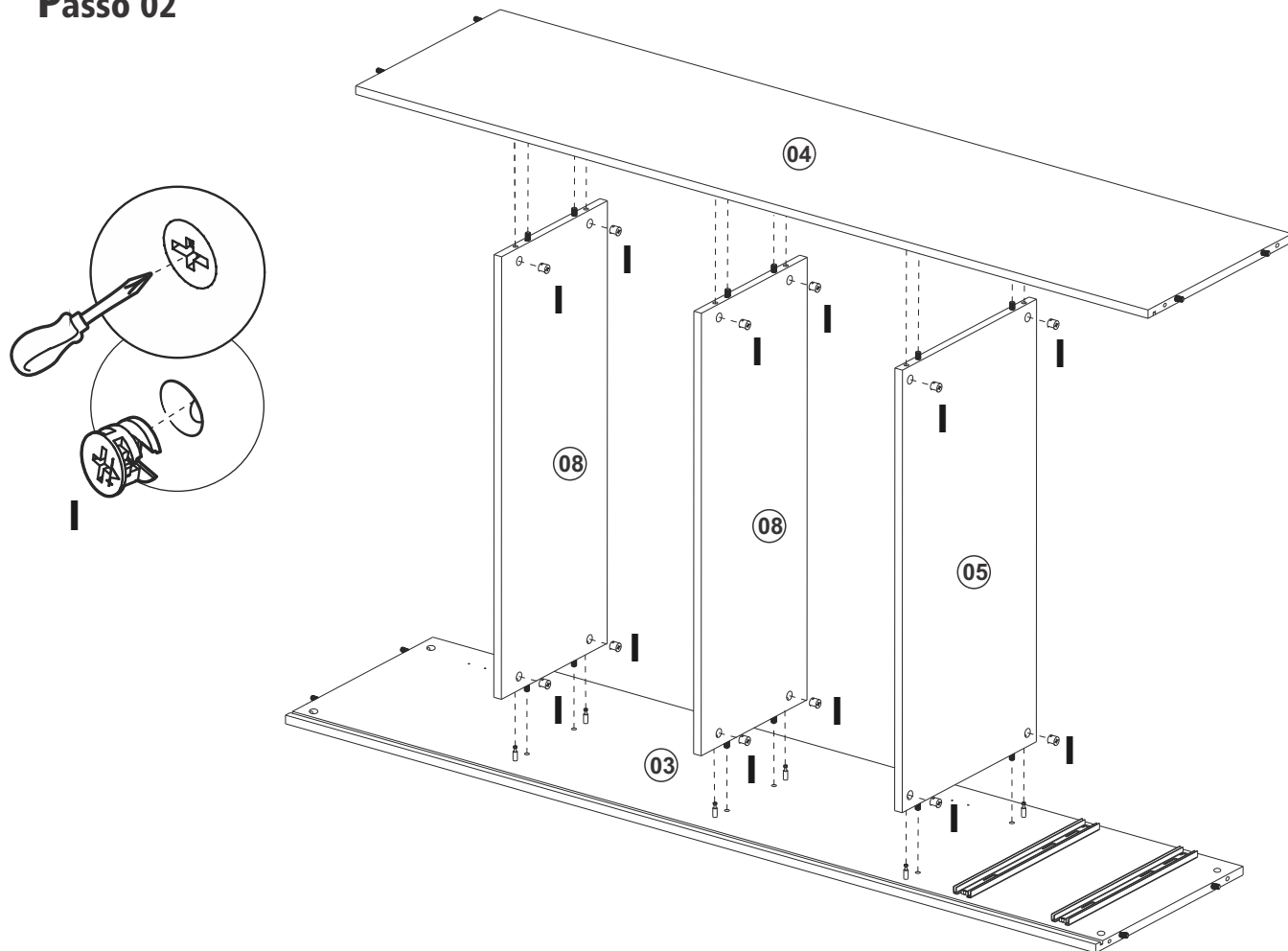

Passo 03

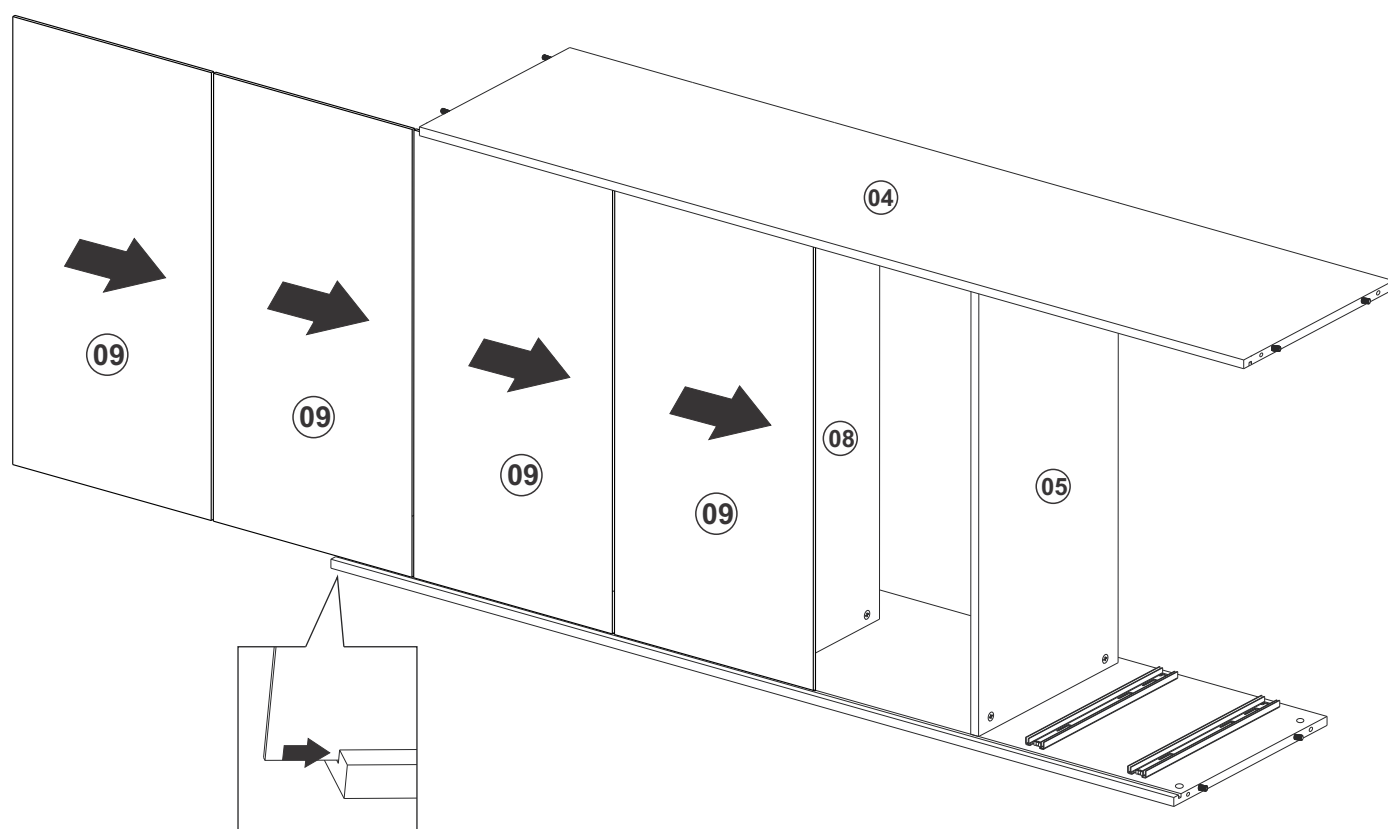

Passo 04
2x

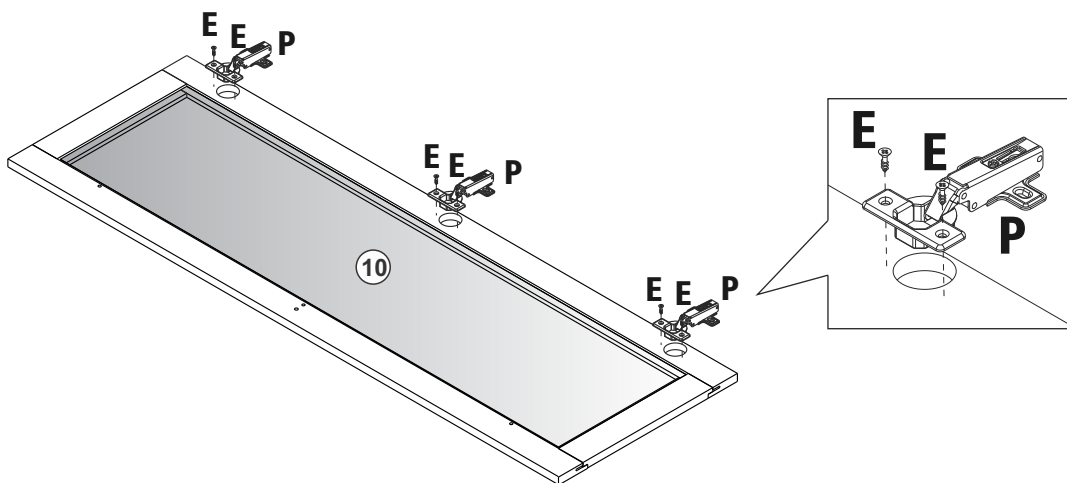

Passo 05

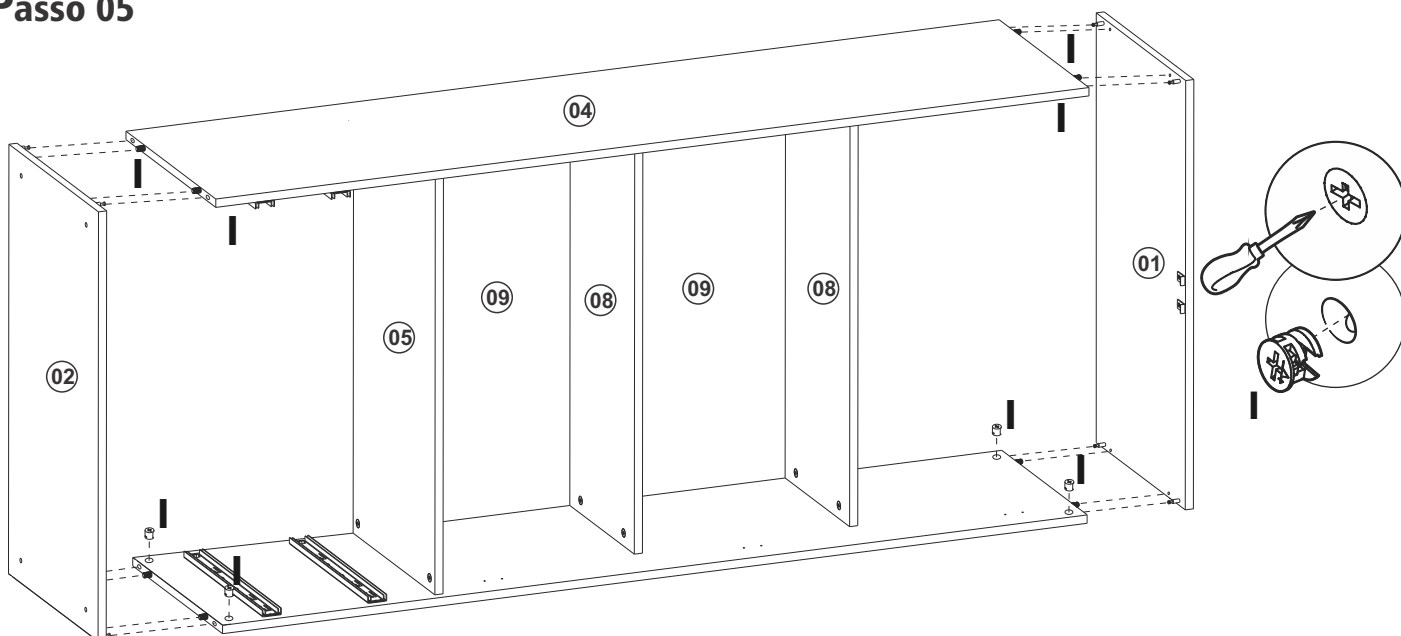

Passo 06

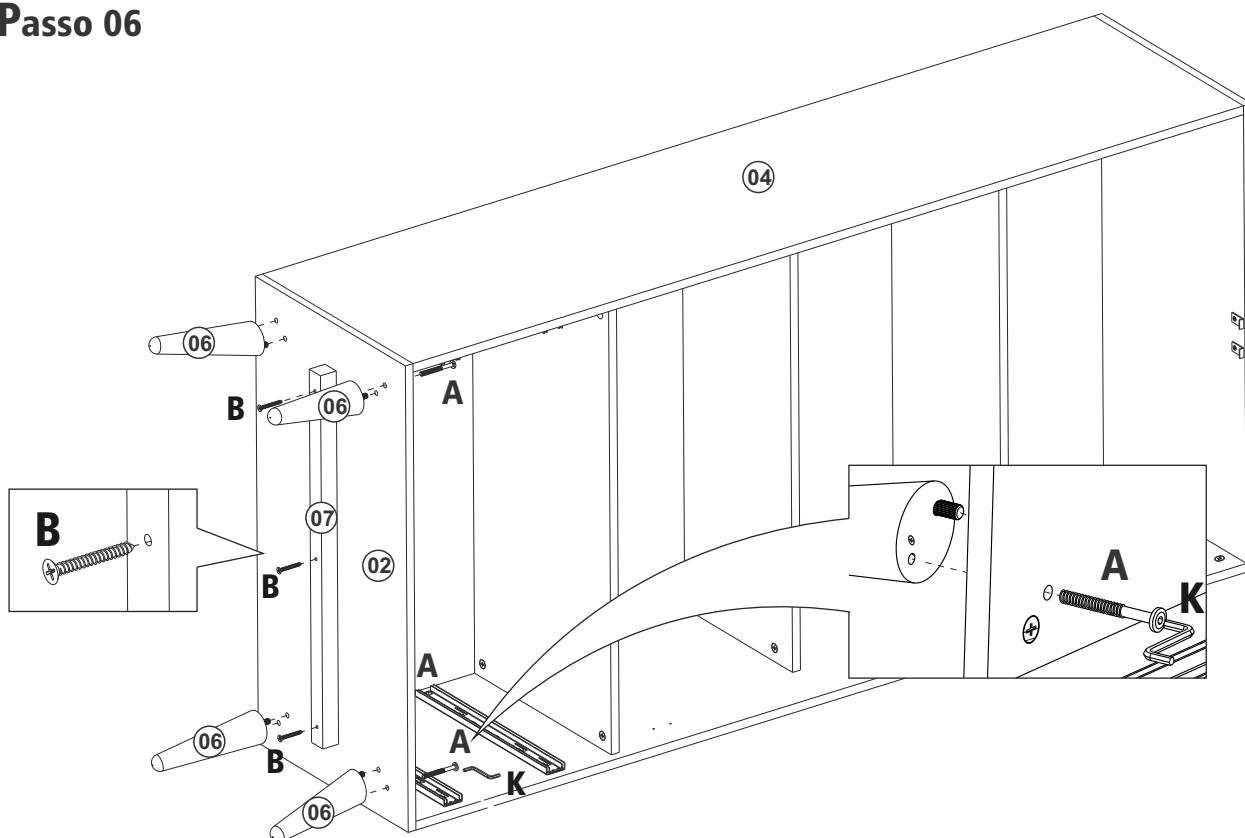

Passo 07

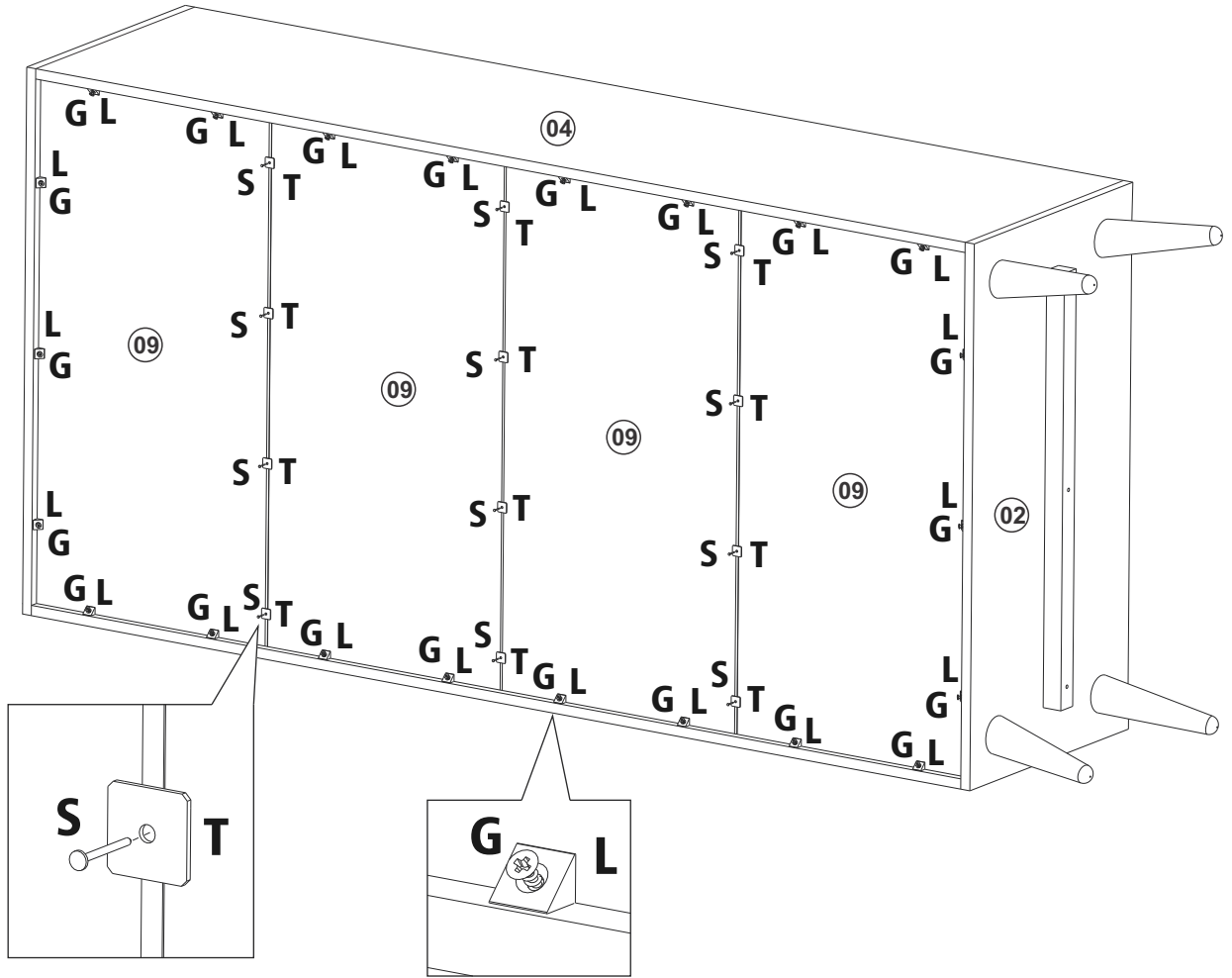

Passo 08 2x

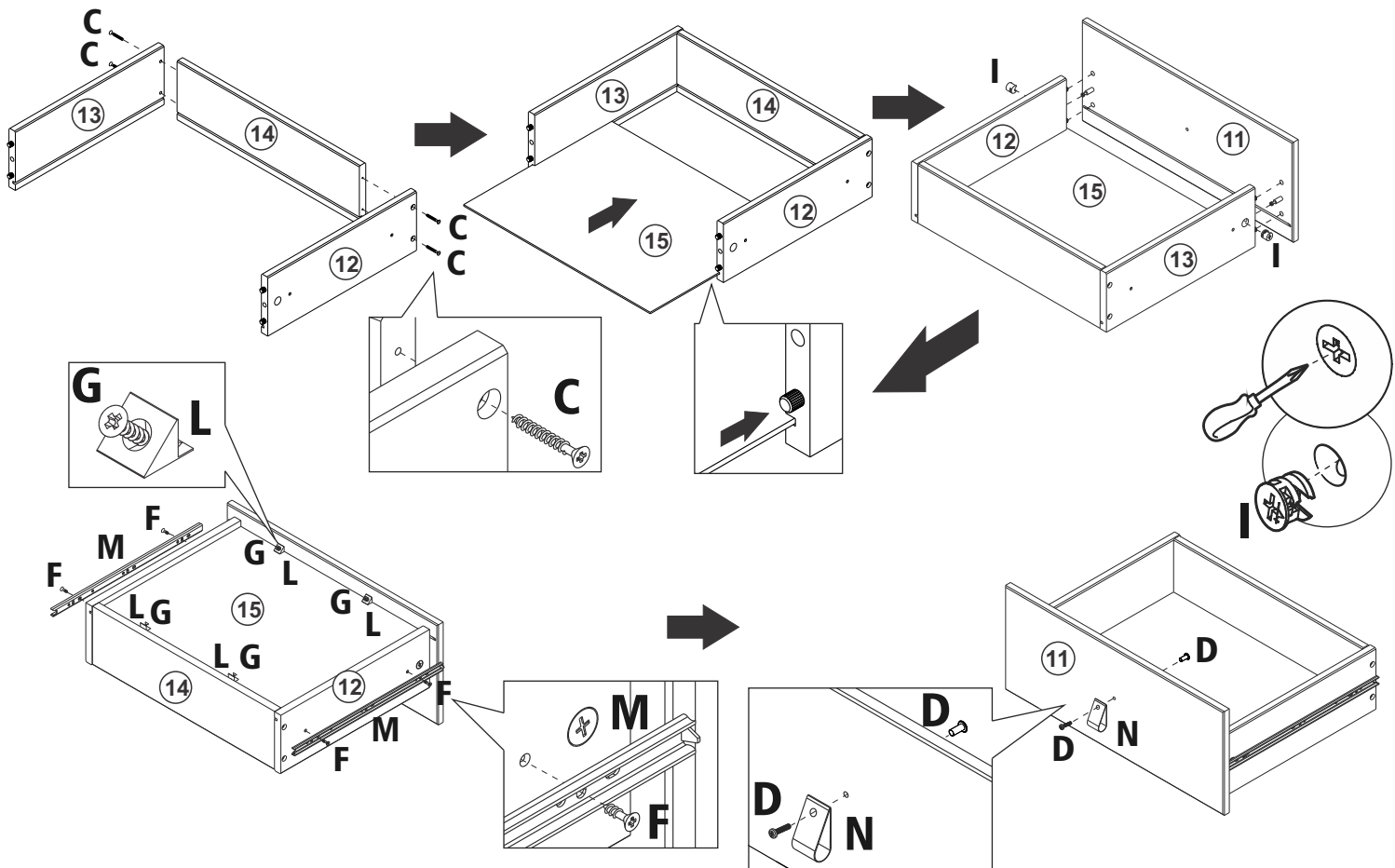

Passo 09

Após a Montagem colar todos os Tapa Furos para melhorar o acabamento do produto.

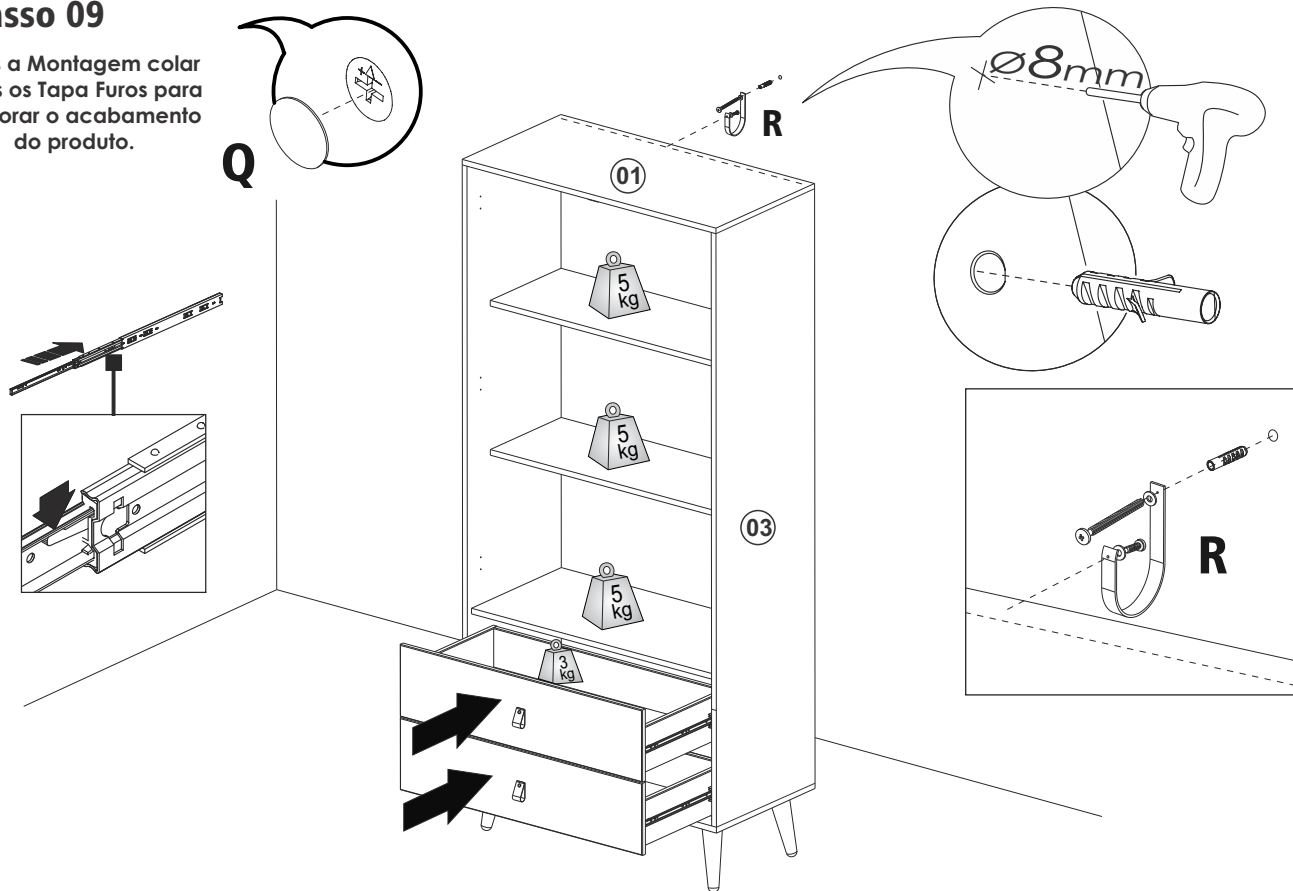

Passo 10

