

Esquema de Montagem

Mesa Cab Ivvie 2G 2N

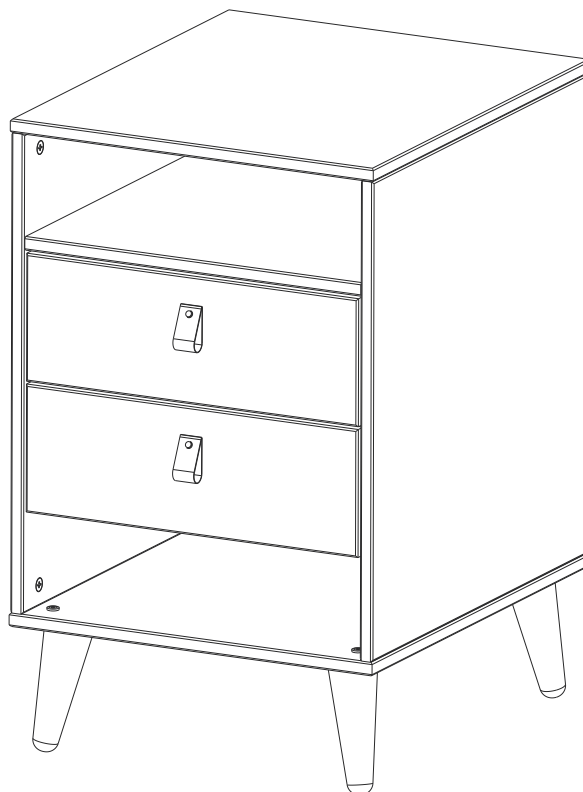

ferramentas necessárias
(não fornecidas)







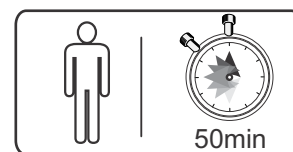

chave phillips

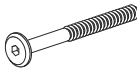

martelo de borracha

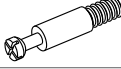

Ferragens

A		7 x 50	04
B		4,0 x 30	08
C		5/32 x 5/8	02
D		3,5 x 14	16
E		3,0 x 16	16
F		Rapid Minifix	16
G		Tambor Minifix	16

H		Ø8x30	20
I		Chave Allen	01
J		Rv8	16
K		Corredixa 350mm	02
L		Puxador	02
M		Tapa Furo	12
N		Ø6x30	04

Passo 02

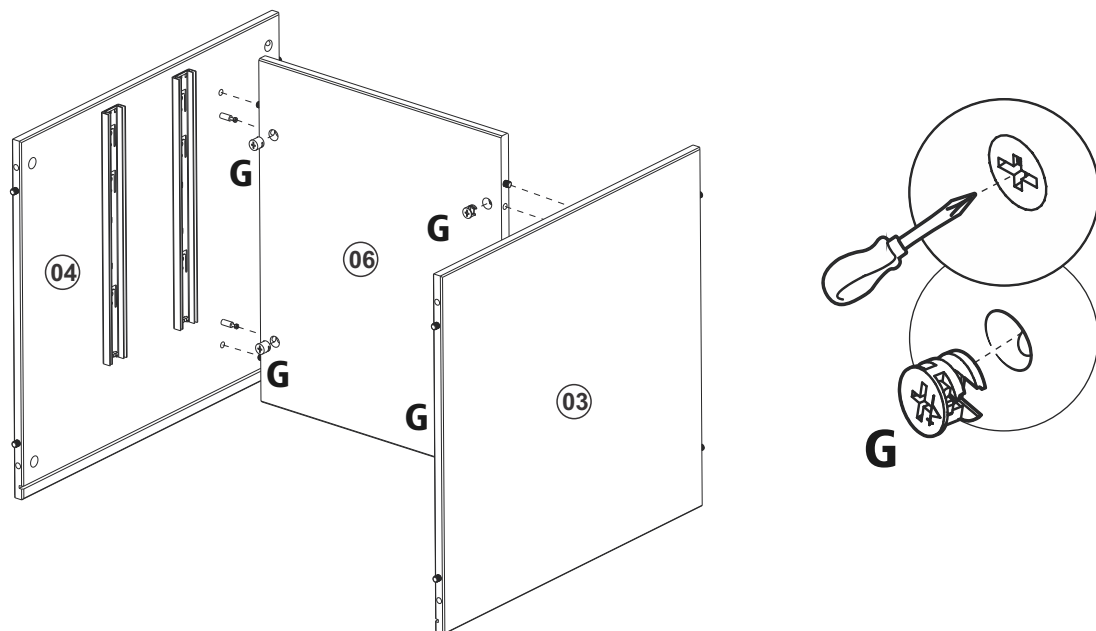

Passo 03

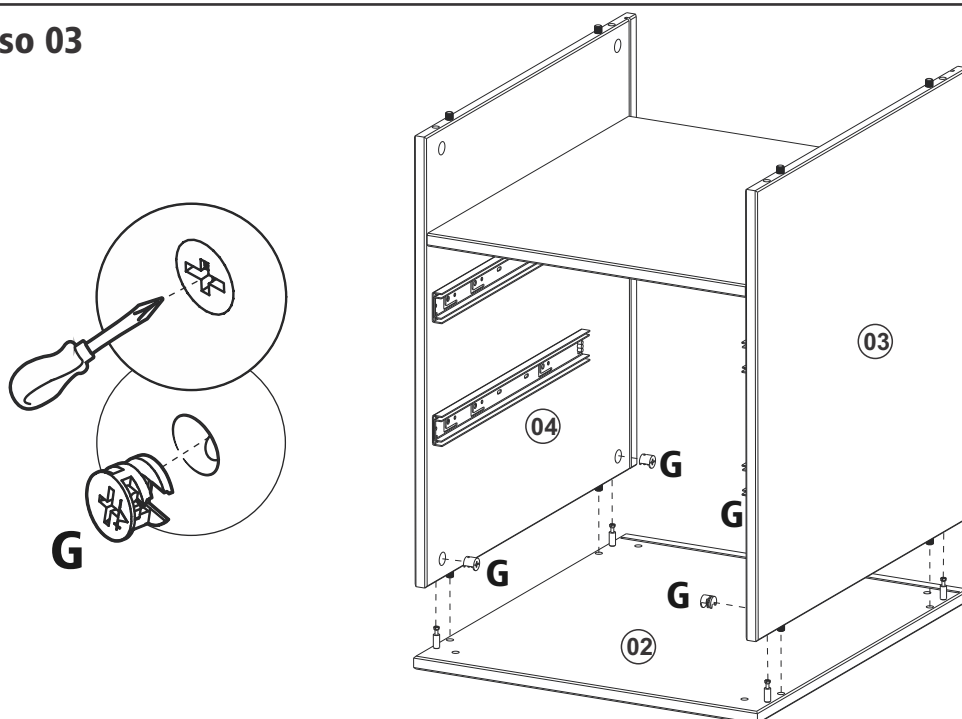

Passo 04

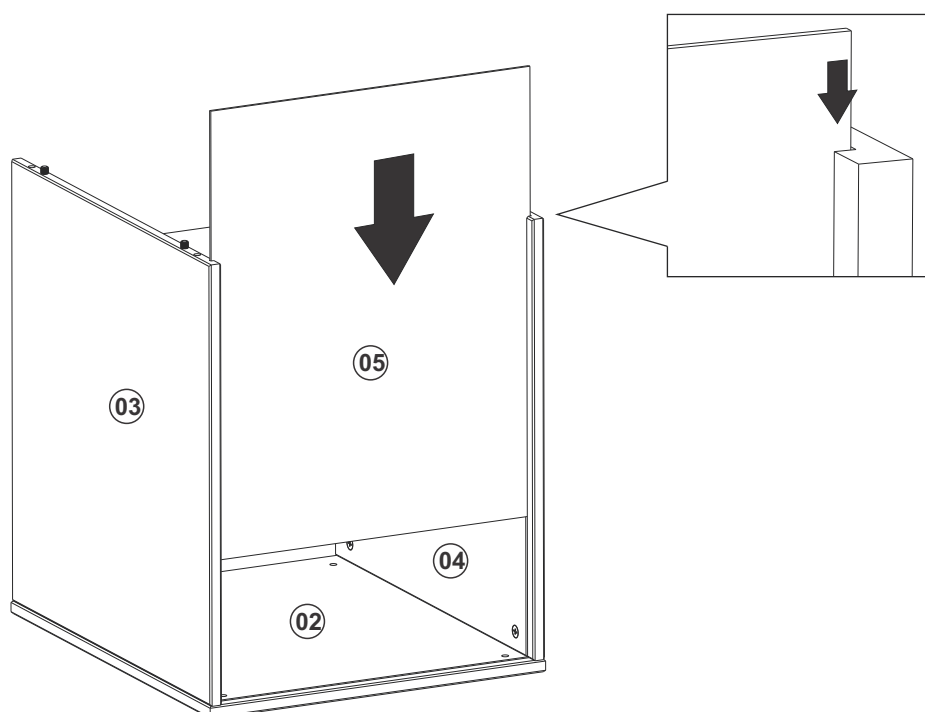

Passo 05

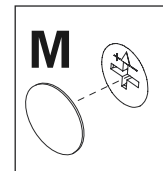
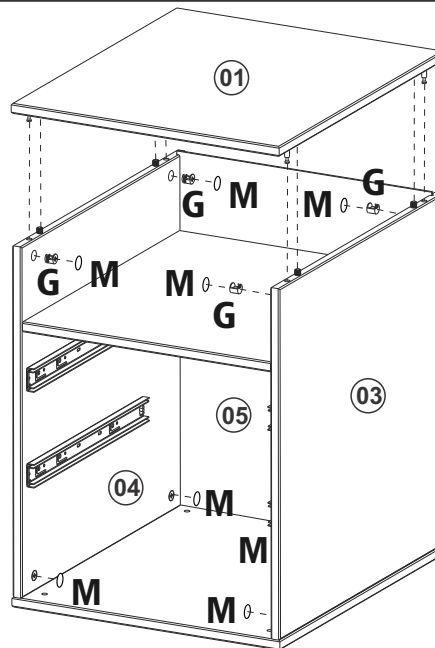
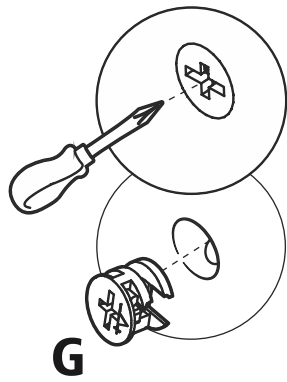

Colar os Tapa Furos para melhorar o acabamento do produto.

Passo 06

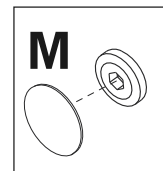
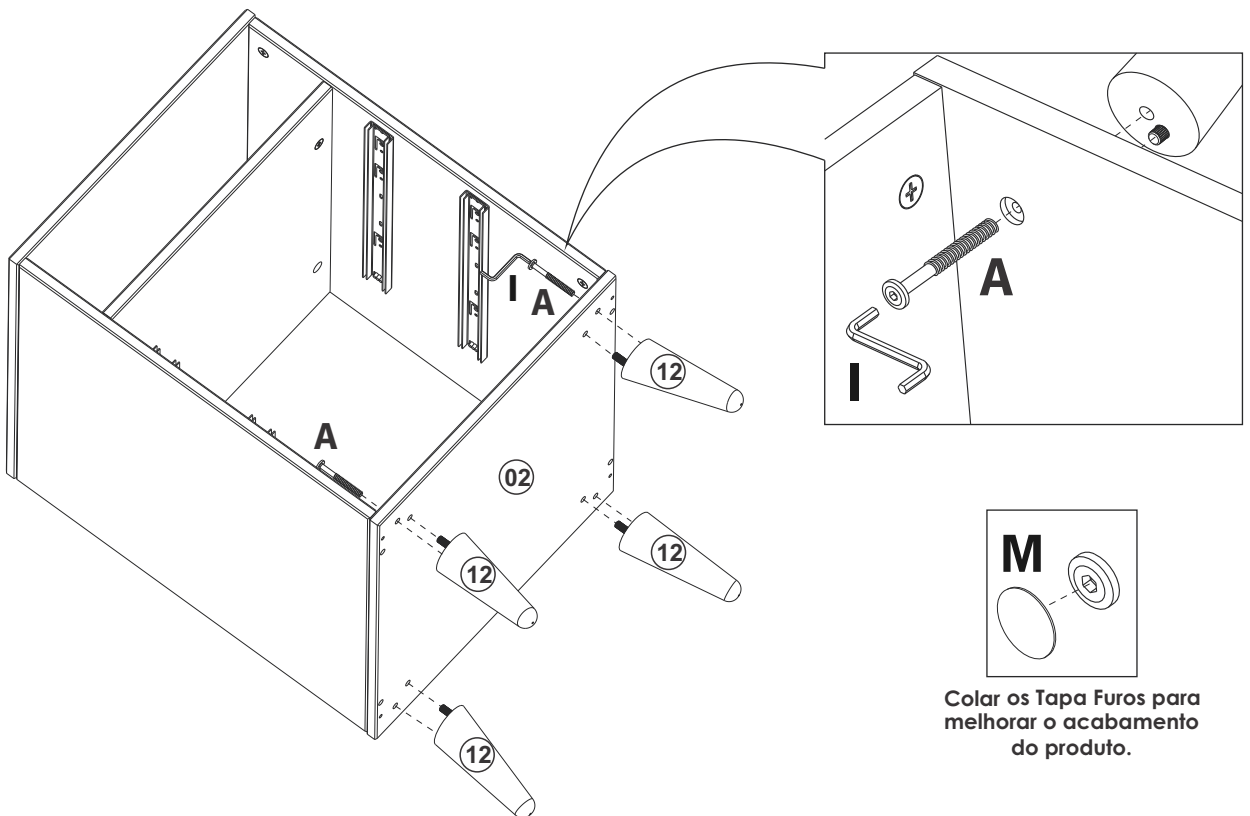

Colar os Tapa Furos para melhorar o acabamento do produto.

Passo 07

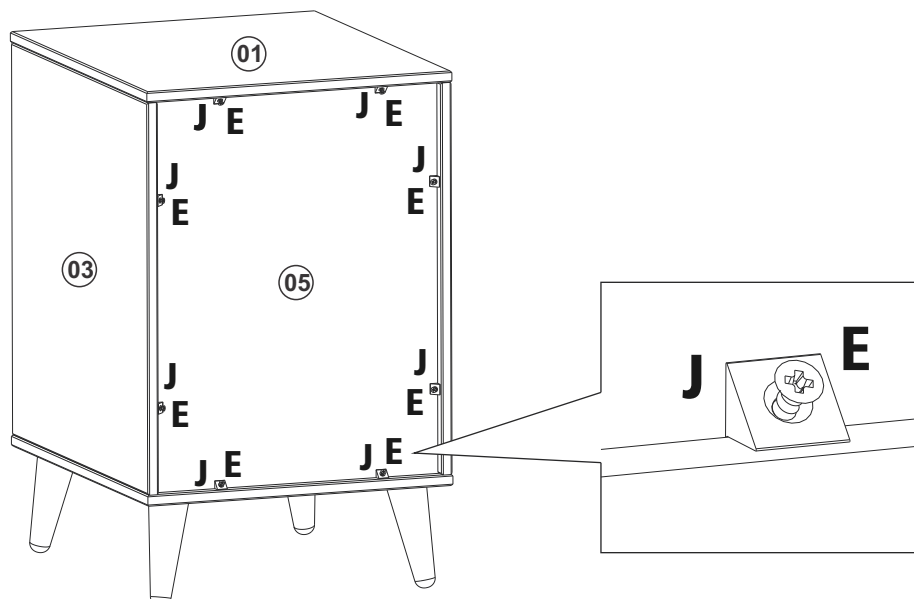

Passo 08 2x

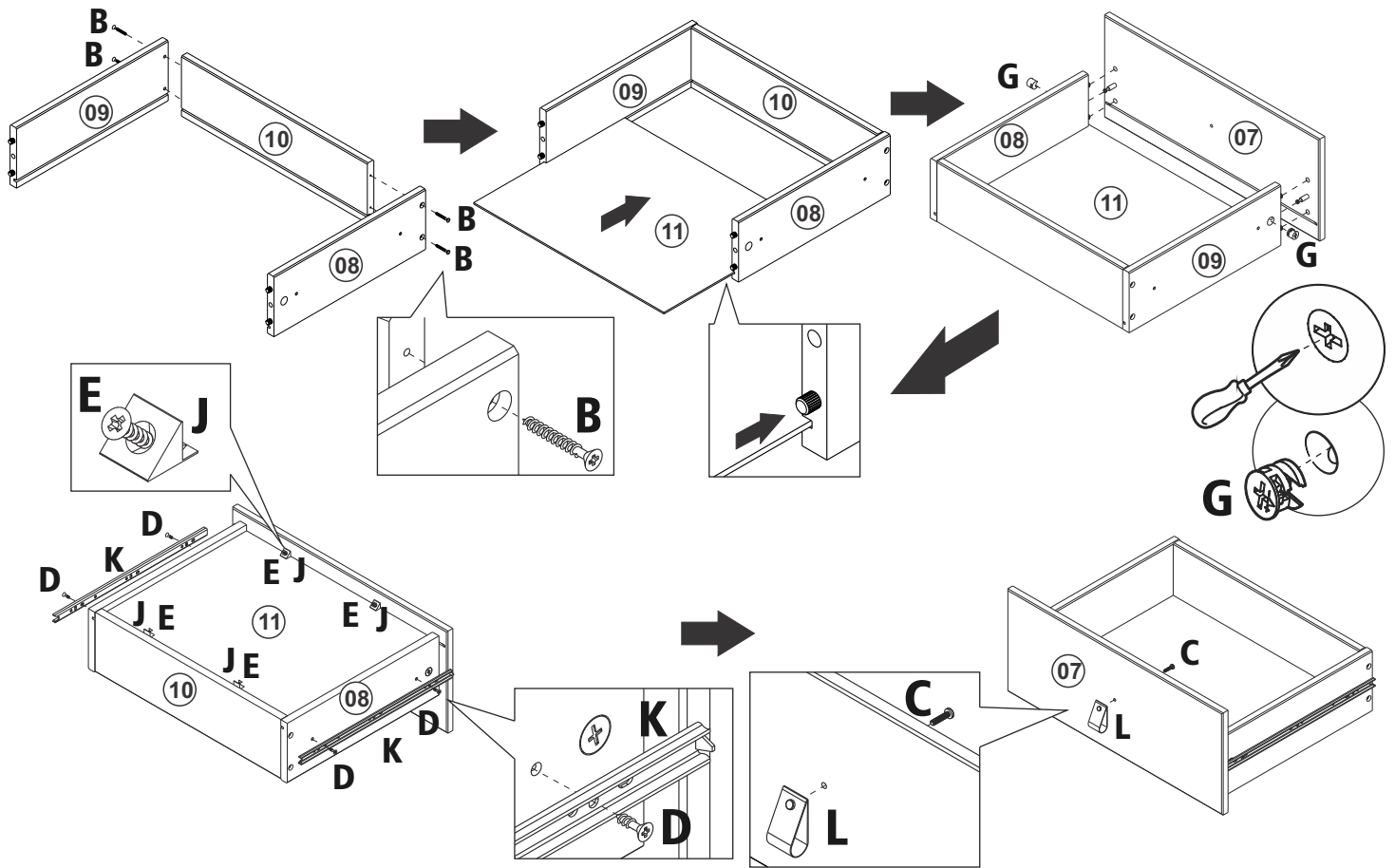

Passo 09

