

Esquema de Montagem

Cômoda 3 Gavetas

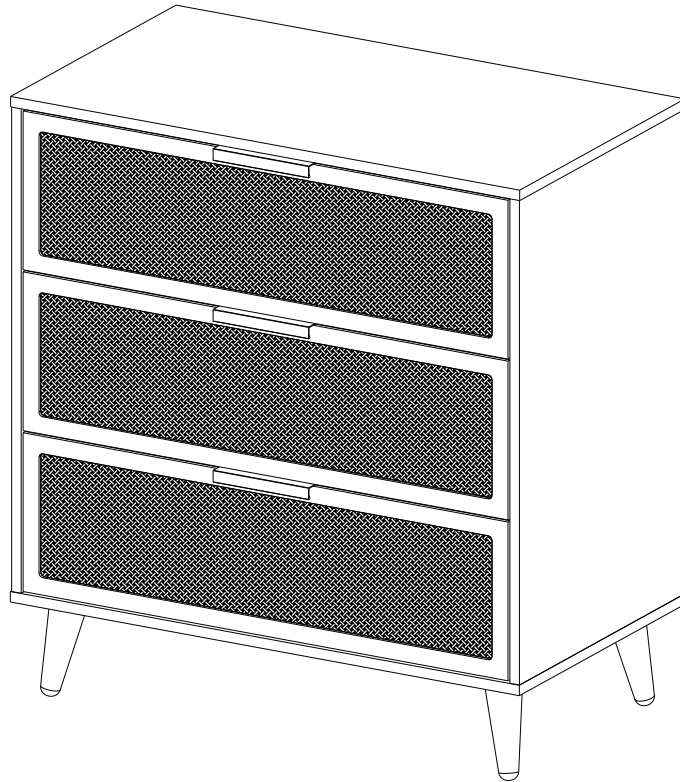

ferramentas necessárias
(não fornecidas)







chave phillips

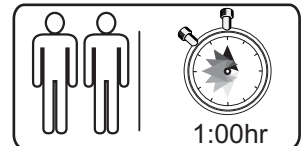



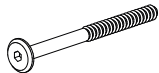
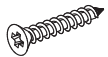

martelo de borracha

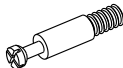

Ferragens

A		7 x 50	04
B		4,0 x 30	12
C		3,5 x 14	30
D		3,0 x 16	24
E		Ø8x30	20
F		Ø6x30	04
G		Rapid Minifix	14

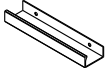
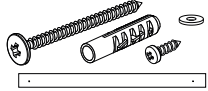
H		Tambor Minifix	14
I		Chave Allen	01
J		Rv8	24
K		Corrediça 350mm	06
L		Puxador	03
M		Kit Antitombamento	01

Componentes

N.	Componentes	Quant.
01	Tampo	01
02	Fundo	01
03	Lateral Direita	01
04	Lateral Esquerda	01
05	Traseira	01
06	Perfil H	01
07	Pé	04
08	Frente de Gaveta	03
09	Lateral Direita de Gaveta	03
10	Lateral Esquerda de Gaveta	03
11	Traseira de Gaveta	03
12	Fundo de Gaveta	03

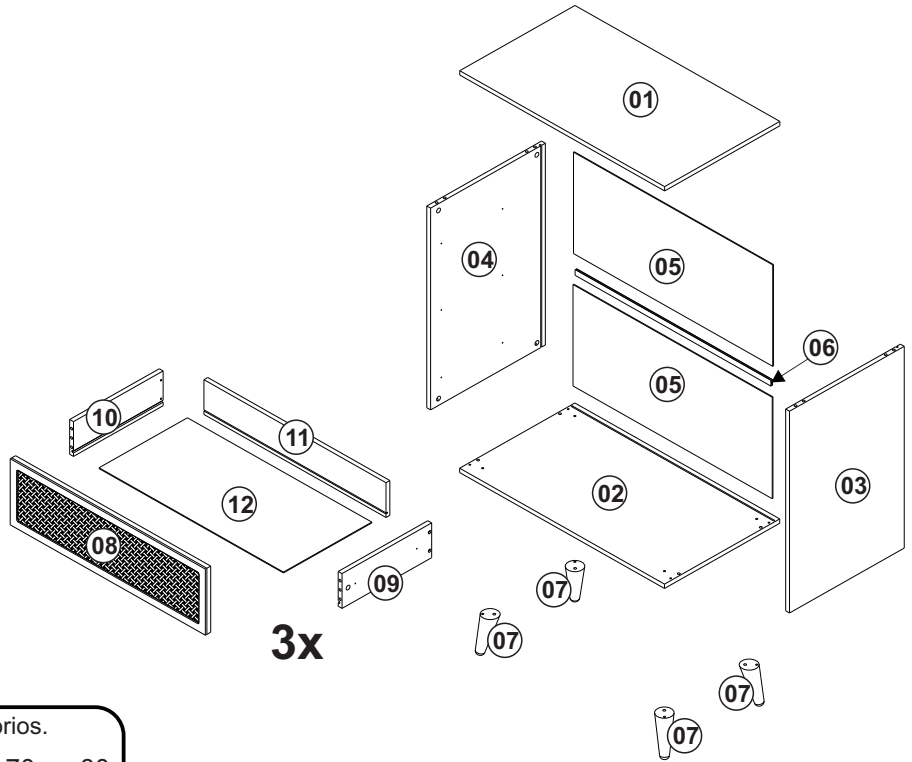

Atenção!
Forrar o chão com o papelão das embalagens para efetuar a montagem.



Passo 01

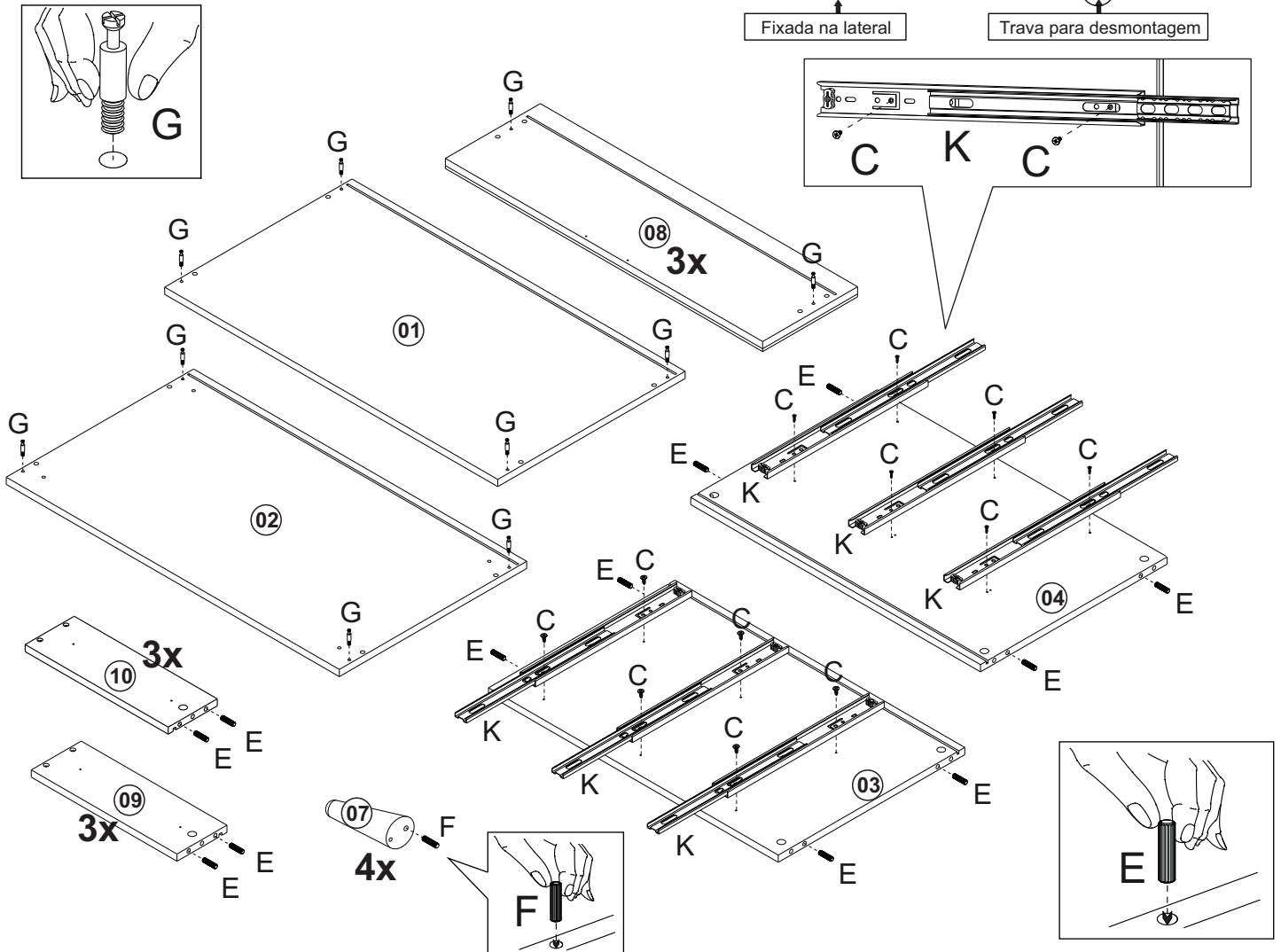

Passo 02

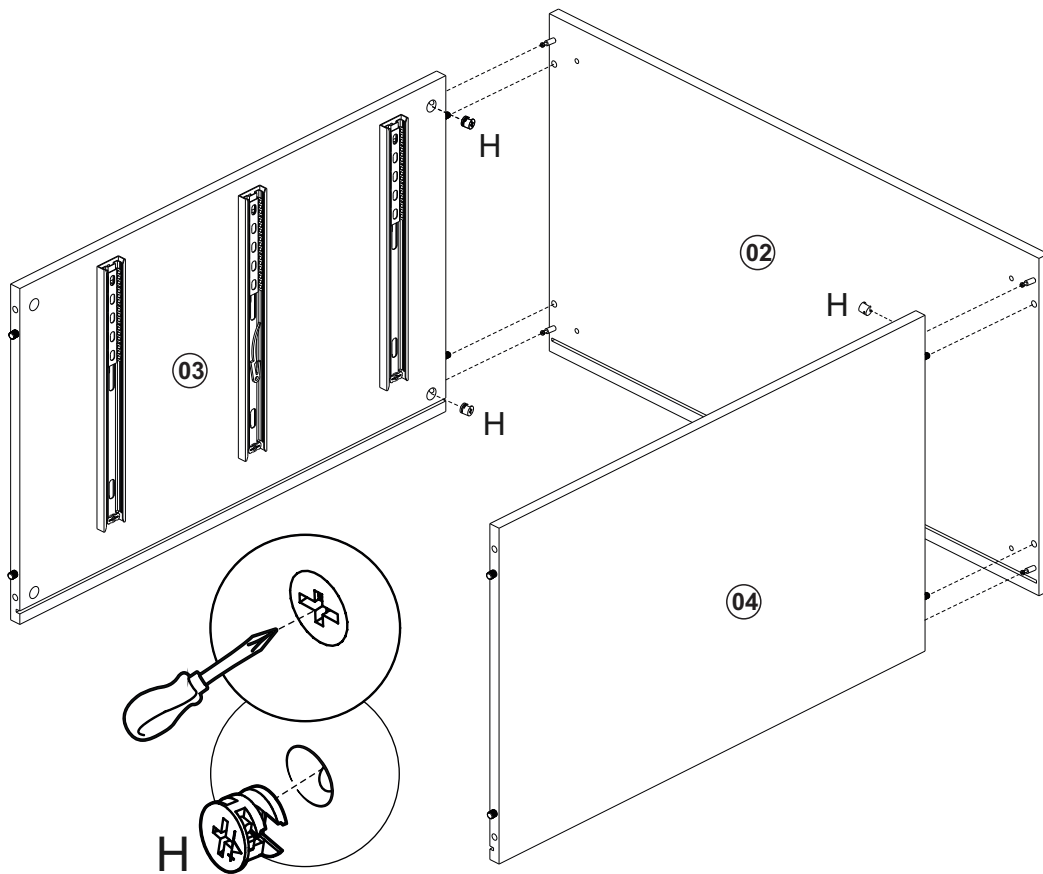

Passo 03

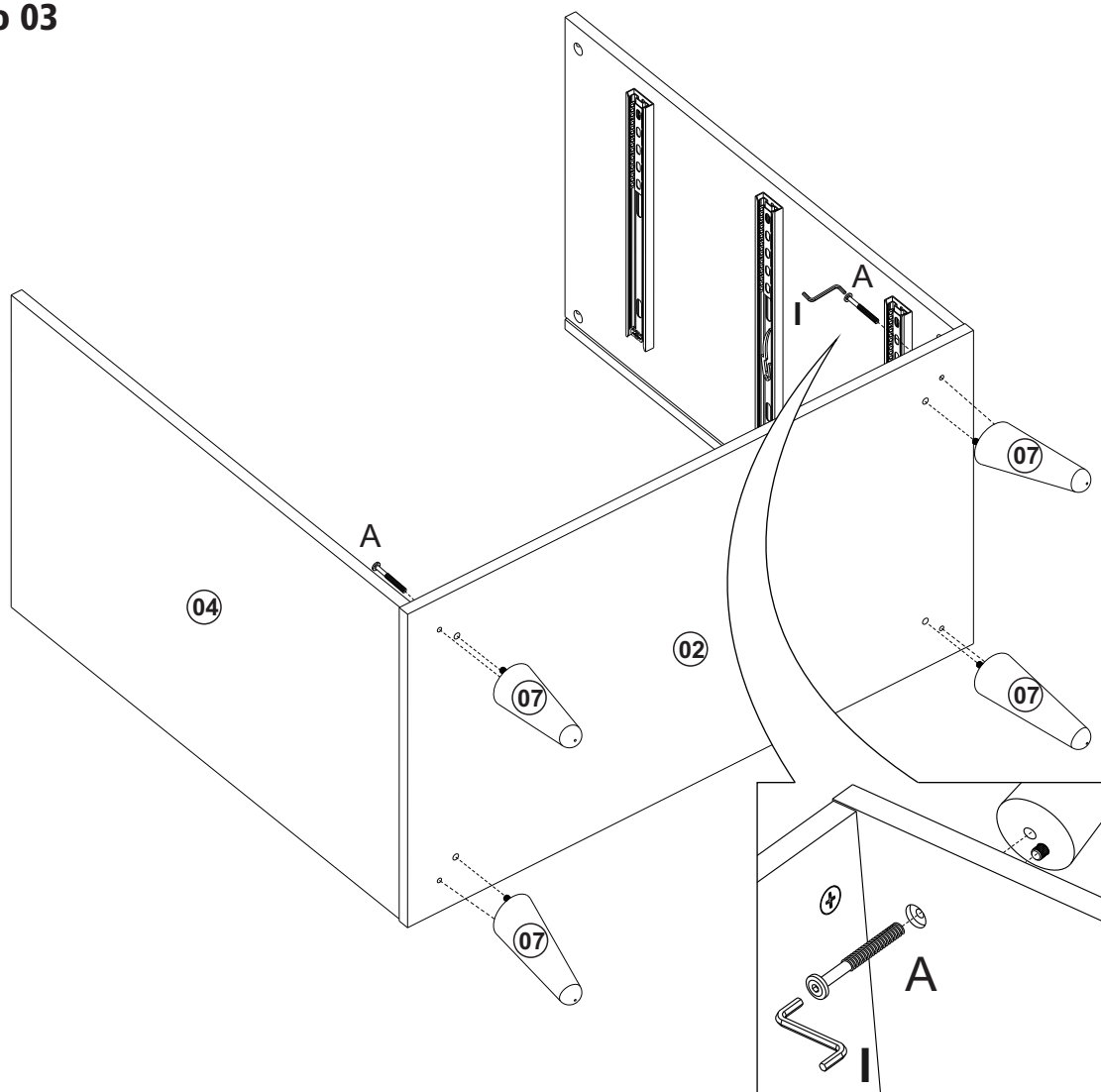

Passo 04

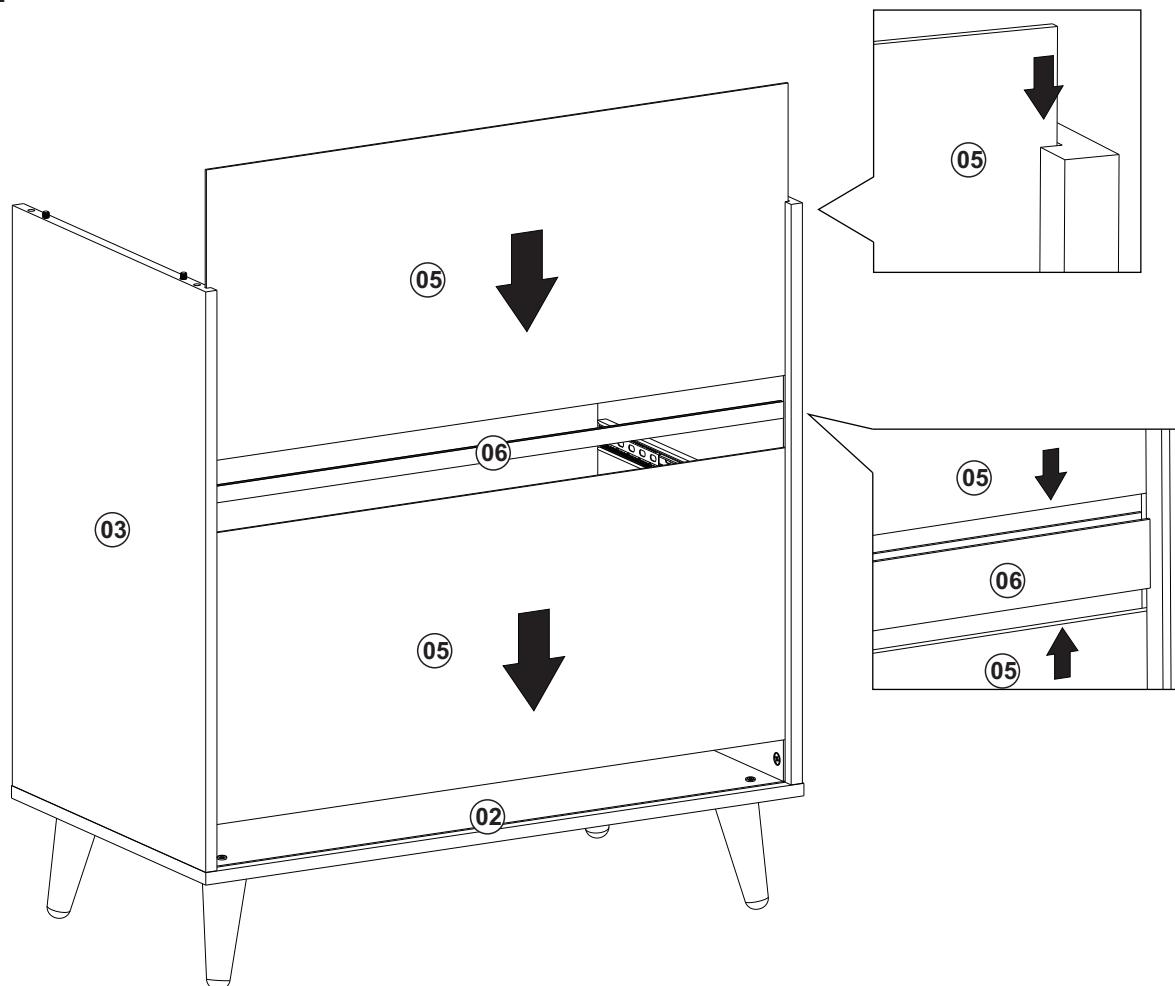

Passo 05

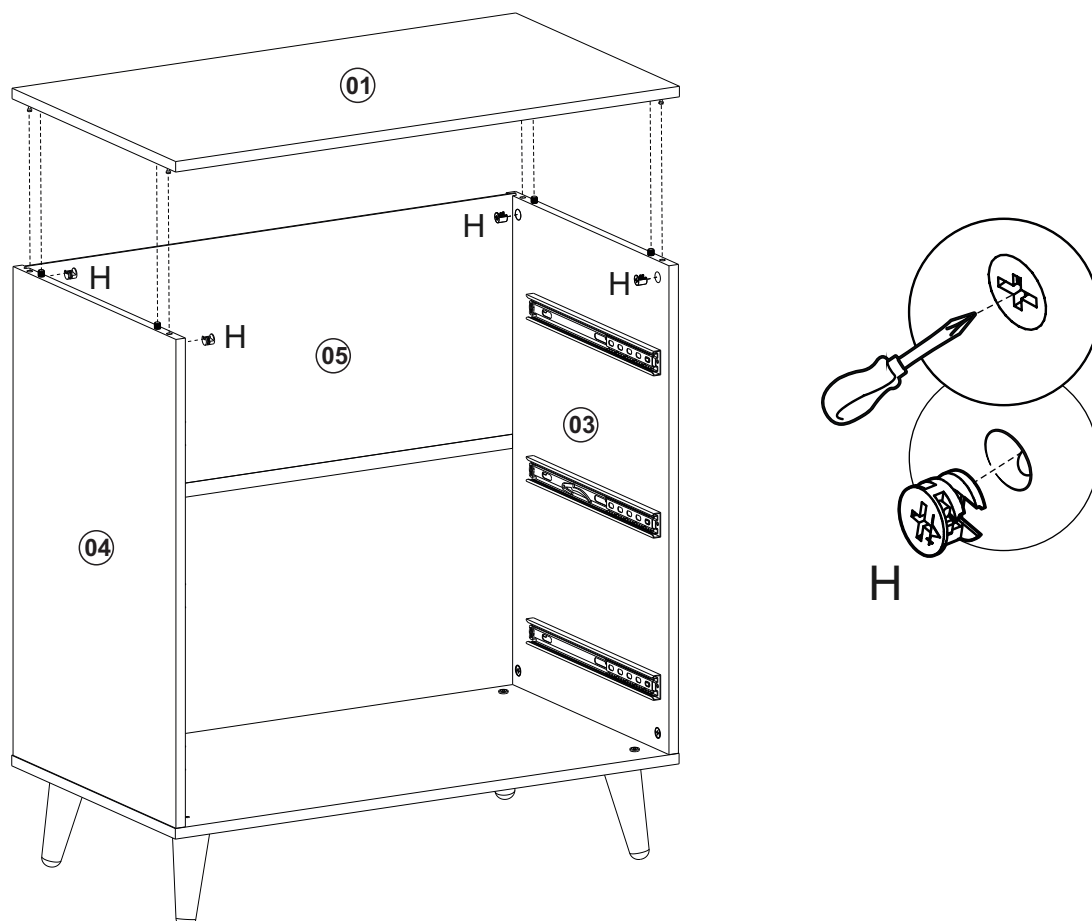

Passo 06

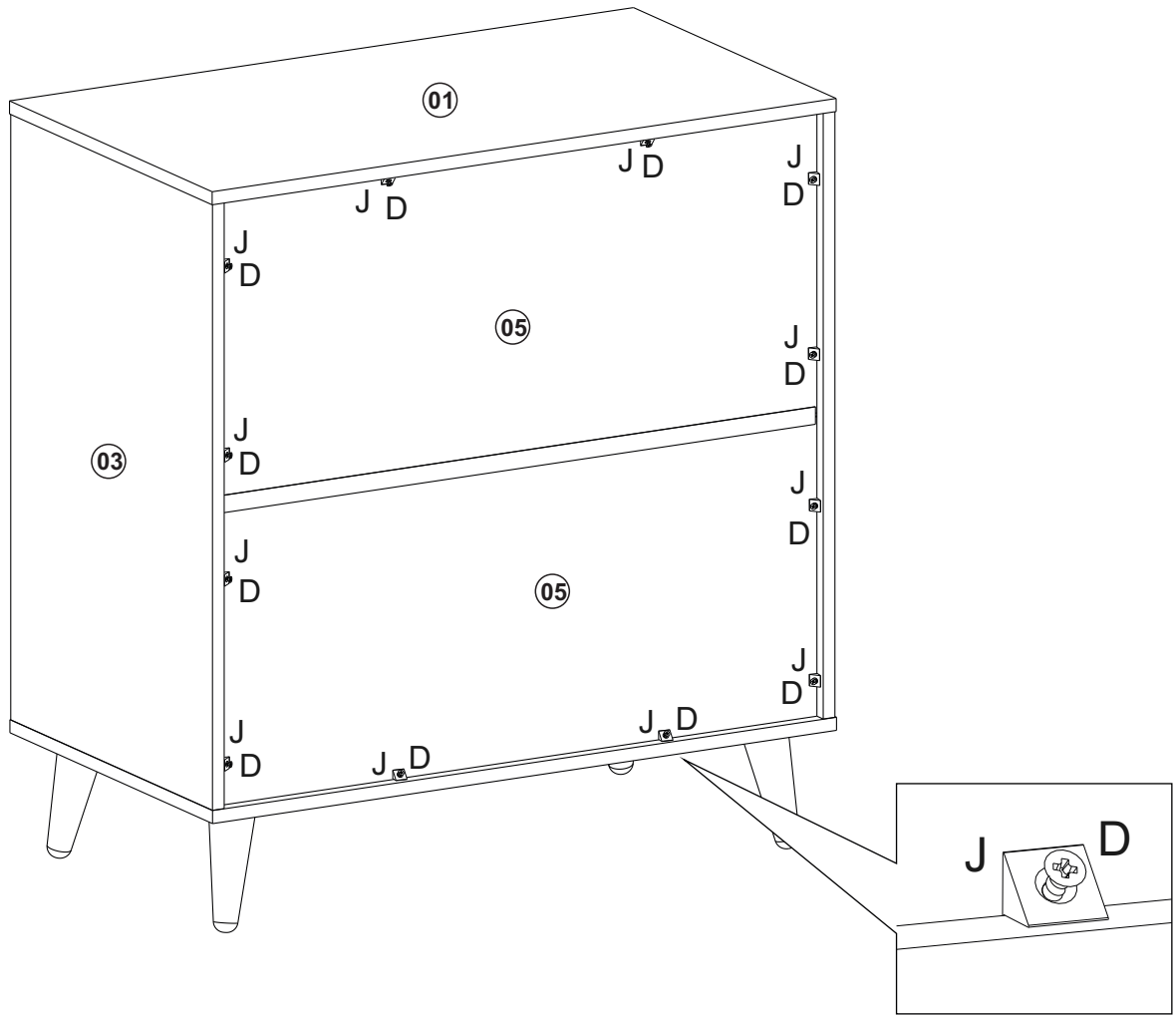

Passo 07 3x

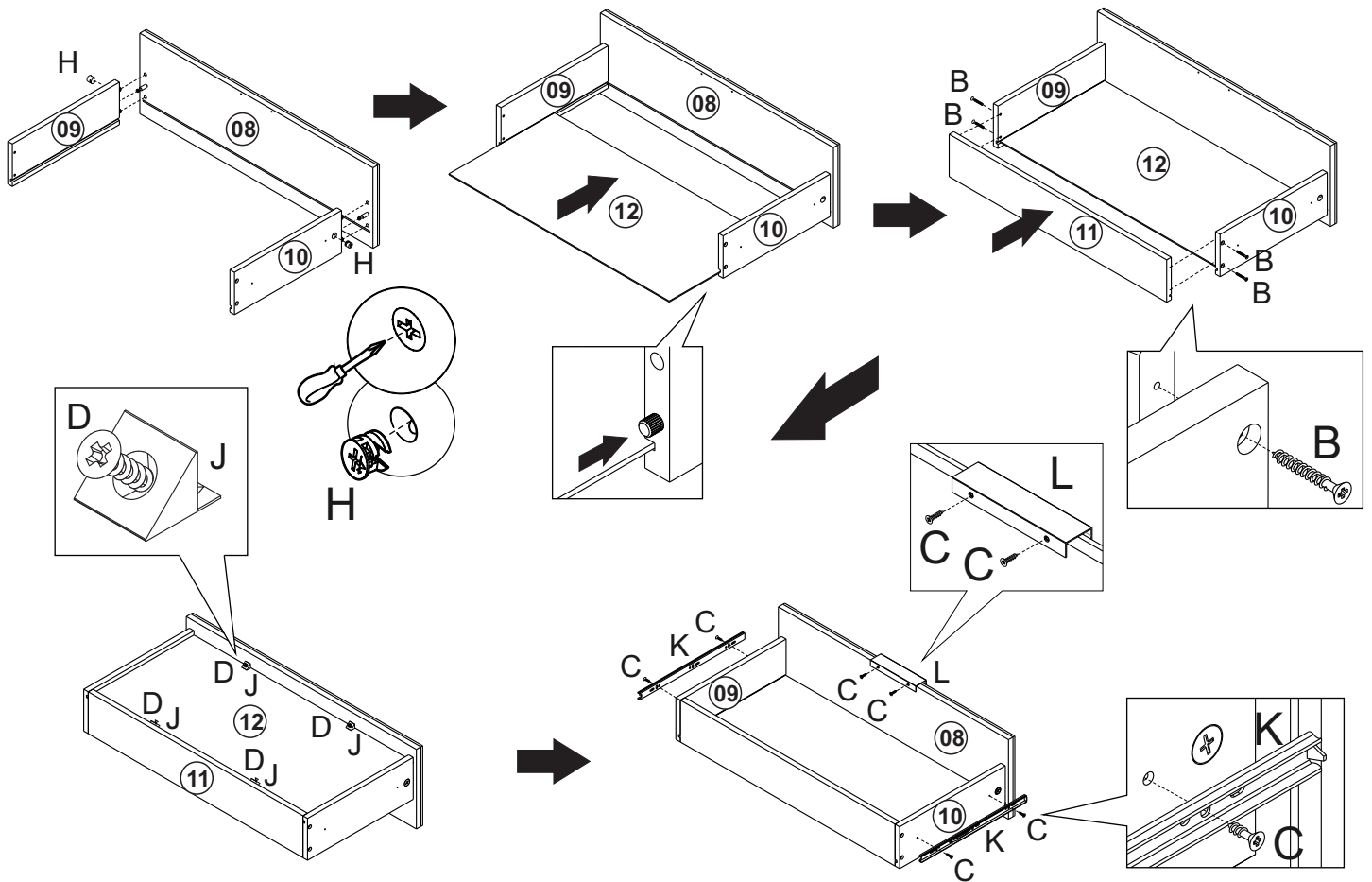

Passo 08

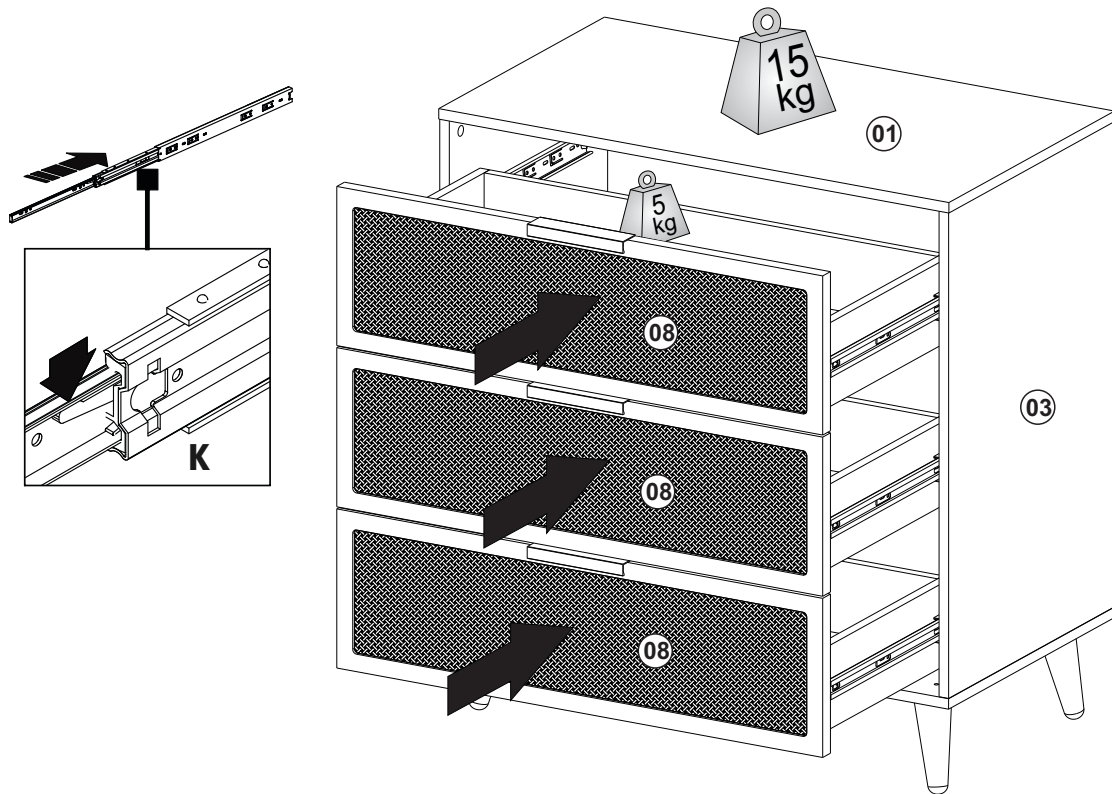

Passo 09

