

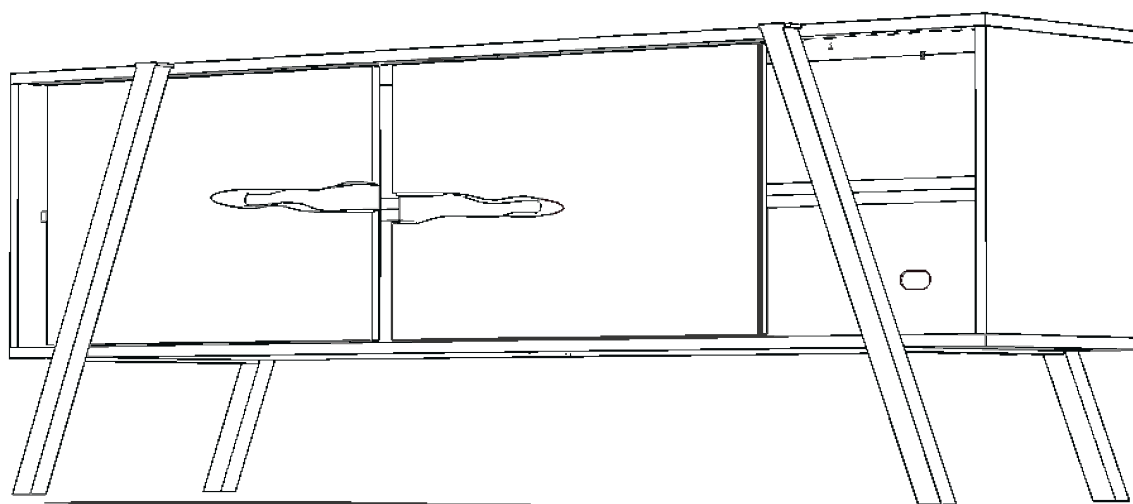

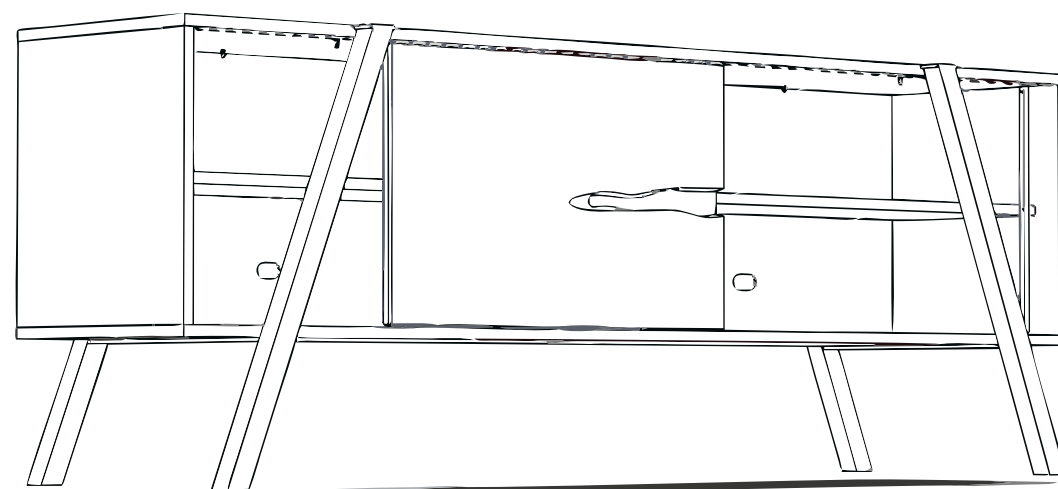

MÓVEL TV SOHO 1 PORTA / SOHO TV MOBILE 1 PUERTA /
TV CONSOLE SOHO 1 DOOR / TÉLÉVISION MOBILE SOHO 1 PORTE

MÓVEL TV SOHO 2 PORTAS / SOHO TV MOBILE 2 PUERTA /
TV CONSOLE SOHO 2 DOORS / TÉLÉVISION MOBILE SOHO 2 PORTES

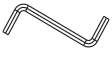

LISTA DE FERRAGEM / LISTA DE HERRAMIENTAS / HARDWARE LIST / LISTE DE LA QUINCAILLERIE

A		1/4X20mm	06
B	 ou 		01
C		1/4"x13mm	06

LISTA DE PEÇAS / LISTA DE PIEZAS / PART LIST / LISTE DES PIÈCES

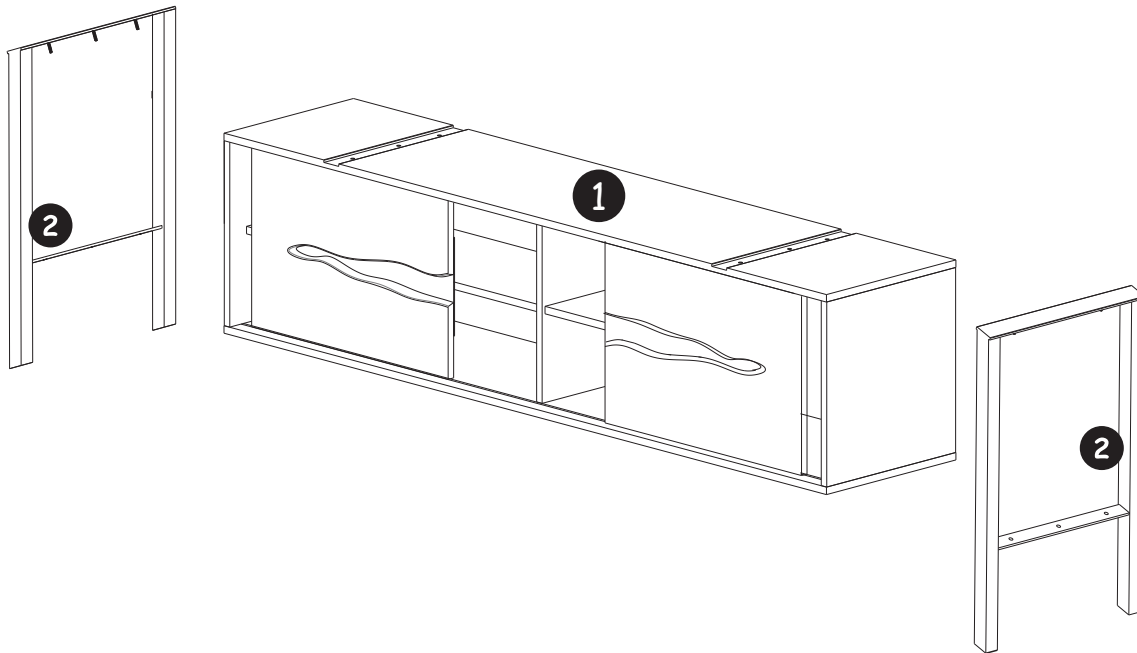

FERRAMENTAS REQUERIDAS (NÃO INCLUSO) / HARDWARE NECESARIO (NO SE INLUYE)

TOOLS REQUIRED (NOT INCLUDED) / OUTILS REQUIS (NON INCLUS)

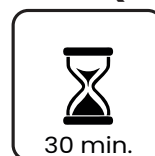
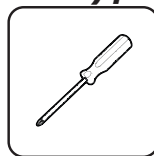
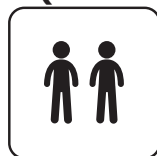

IMPORTANT / IMPORTANT

* A montagem deste produto deve ser feita em uma superfície limpa e plana, nós recomendamos para usar a embalagem para proteger o produto durante a montagem. Os parafusos não podem ser exageradamente apertados para evite tirar as porcas de metal internas.

* Este producto debe montarse en una superficie limpia y plana, recomendamos utilizar el envase para proteger el producto durante el montaje. Los tornillos no deben apretarse en exceso para evitar que se desprendan las tuercas metálicas internas.

* The assembly of this product should be done in a clean and flat surface we recommended to use the carton to protect the product during assembly. The screws cant be exaggeratedly tight to avoid taking out the internal metal nuts.

* L'assemblage de ce produit doit être effectué sur une surface propre et plane. Nous vous recommandons d'utiliser le carton pour protéger le produit pendant l'assemblage. Les vis ne doivent pas être serrées exagérément pour éviter de casser les écrous métalliques internes.

RECOMENDAÇÕES DE CONSERVAÇÃO E LIMPEZA / RECOMENDACIONES DE MANTENIMIENTO Y LIMPIEZA MAINTENANCE AND CLEANING RECOMMENDATIONS / RECOMMANDATIONS D'ENTRETIEN ET DE NETTOYAGE

* Não usar produtos que contenham em sua formulação álcool ou silicone. Preferencialmente usar um pano seco ou levemente umedecido com água e detergente neutro.

* Instalar o mesmo em locais abrigados de ol e chuva, como também, ambientes com condições extremas de temperatura, luz e umidade. O produto não é feito para uso externo e nem para áreas molhada.

* O local de instalação deve ser próprio, com piso nivelado ou parede resistente e seu uso não deve ser diferente para qual o mesmo foi projetado.

* No utilizar productos que contengan alcohol o silicona en su formulación. Utilizar preferentemente un paño seco o ligeramente humedecido con agua y detergente neutro.

* Instalar la misma en lugares resguardados del sol y la lluvia, así como en ambientes con condiciones extremas de temperatura, luz y humedad, la luz y la humedad. El producto no está diseñado para su uso en exteriores, ni para zonas húmedas.

* El lugar de instalación debe ser adecuado, con suelo nivelado o pared resistente y su uso no debe ser diferente de aquel para el que fue diseñado. el mismo fue diseñado para

* Do not use products that contain alcohol or silicone in their formulation. Preferably use a dry cloth or lightly dampened with water and neutral detergent.

* Install it in places sheltered from the sun and rain, as well as in places with extreme conditions of temperature, light and humidity. The product is not made for external use external use nor for wet areas.

* The installation site must be proper, with a leveled floor or resistant wall and its use must not be different from that for which it was designed.

* N'utilisez pas de produits contenant de l'alcool ou du silicone dans leur formulation. Utiliser de préférence un chiffon sec ou légèrement humecté avec de l'eau et un détergent neutre.

* Installer le même dans des endroits abrités du soleil et de la pluie, ainsi que dans des environnements présentant des conditions extrêmes de température, de lumière et d'humidité, la lumière et l'humidité. Le produit n'est pas conçu pour une utilisation en extérieur, ni pour les zones humides.

* Le lieu d'installation doit être approprié, avec un sol nivelé ou un mur résistant et son utilisation ne doit pas être différente de celle pour laquelle il a été conçu. pour lequel il a été conçu.

IMPORTANTE / IMPORTANT

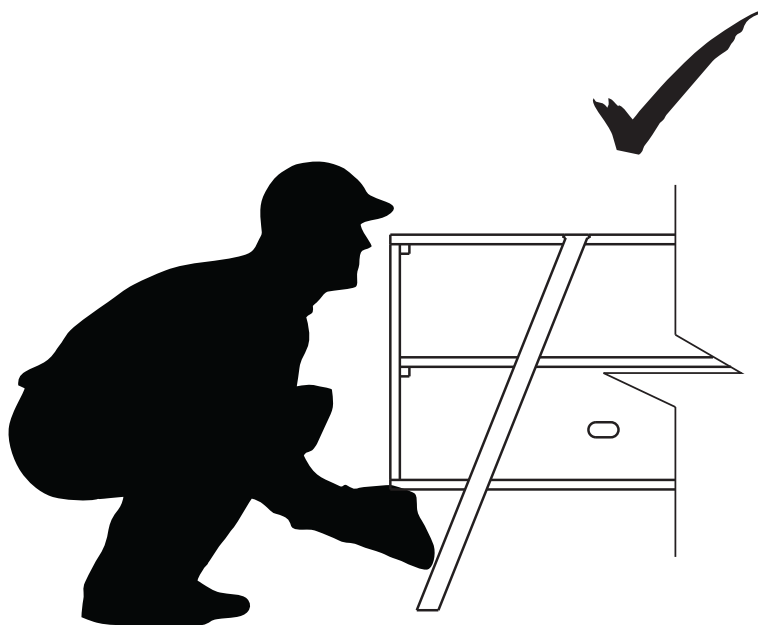

3

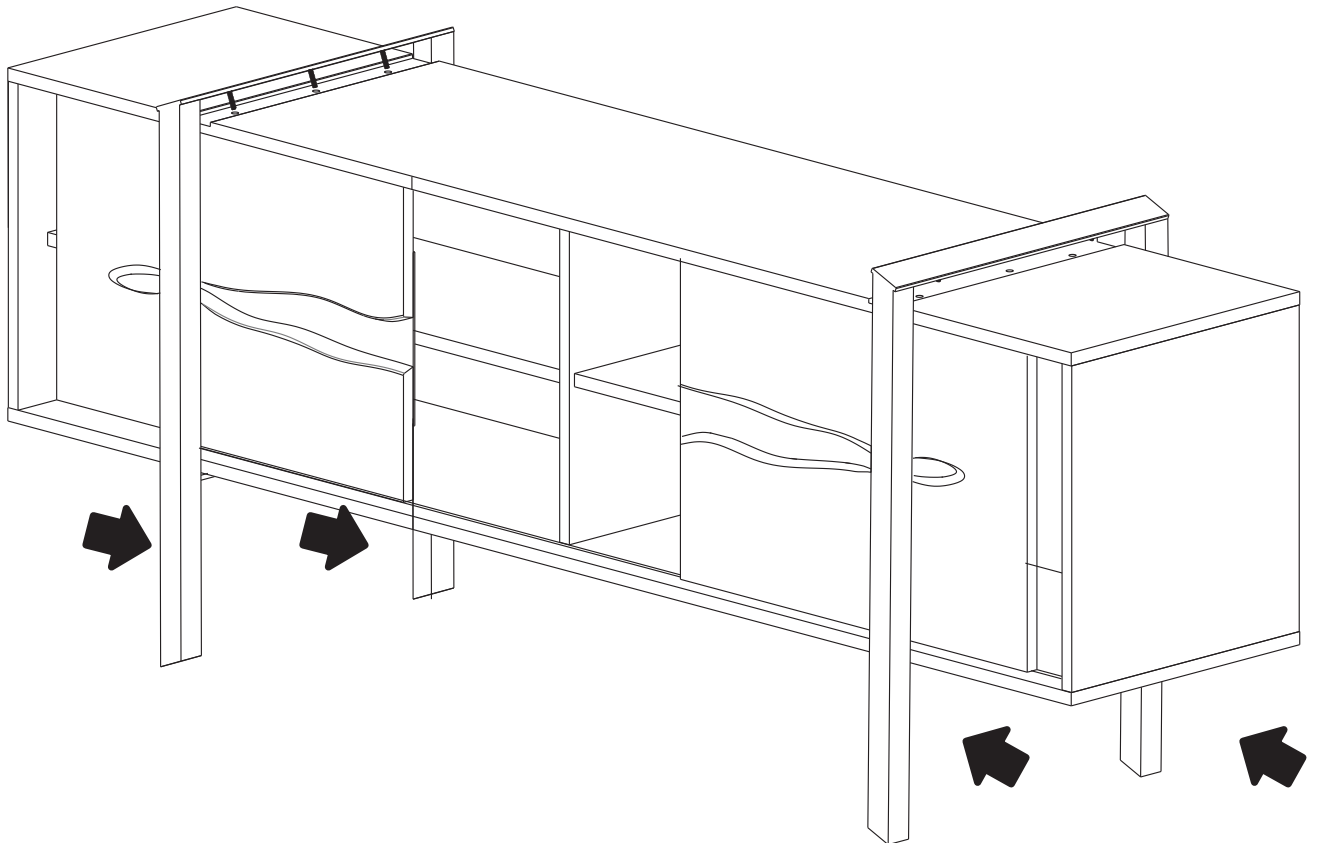
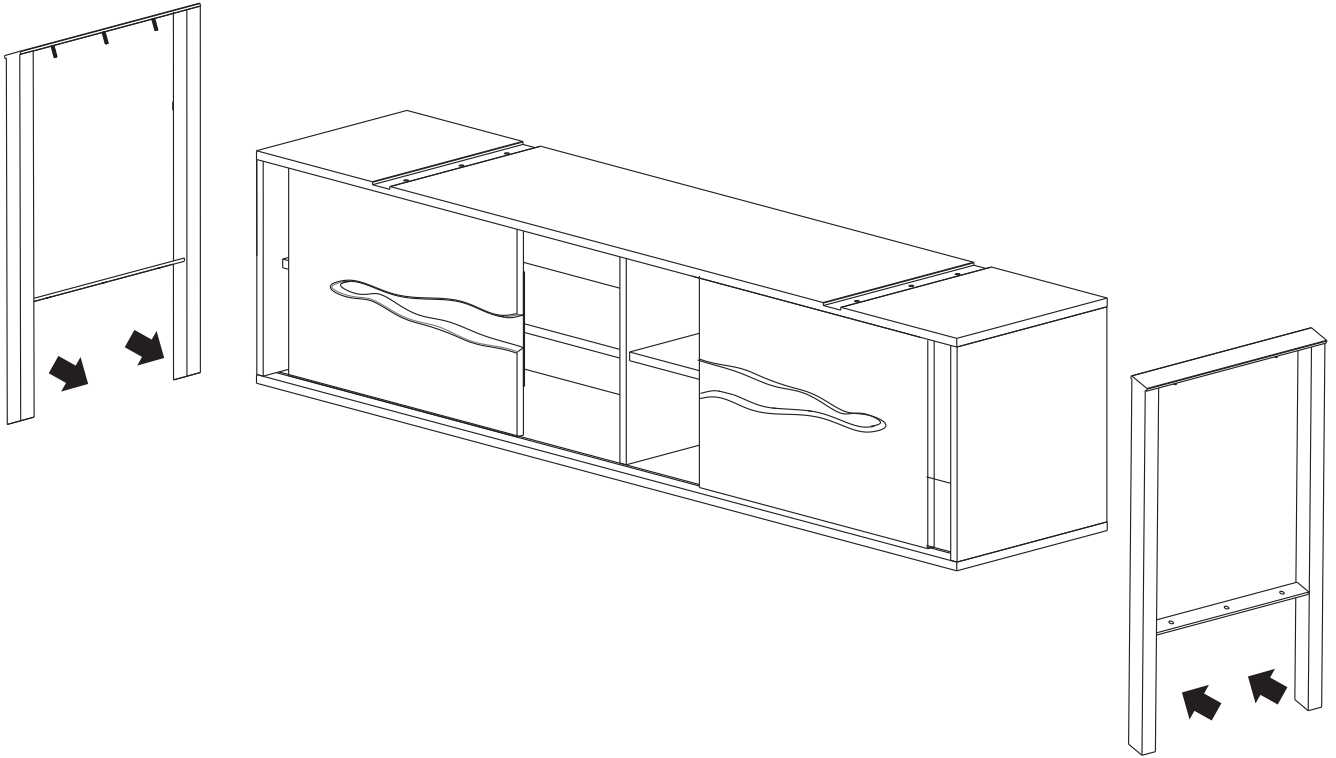

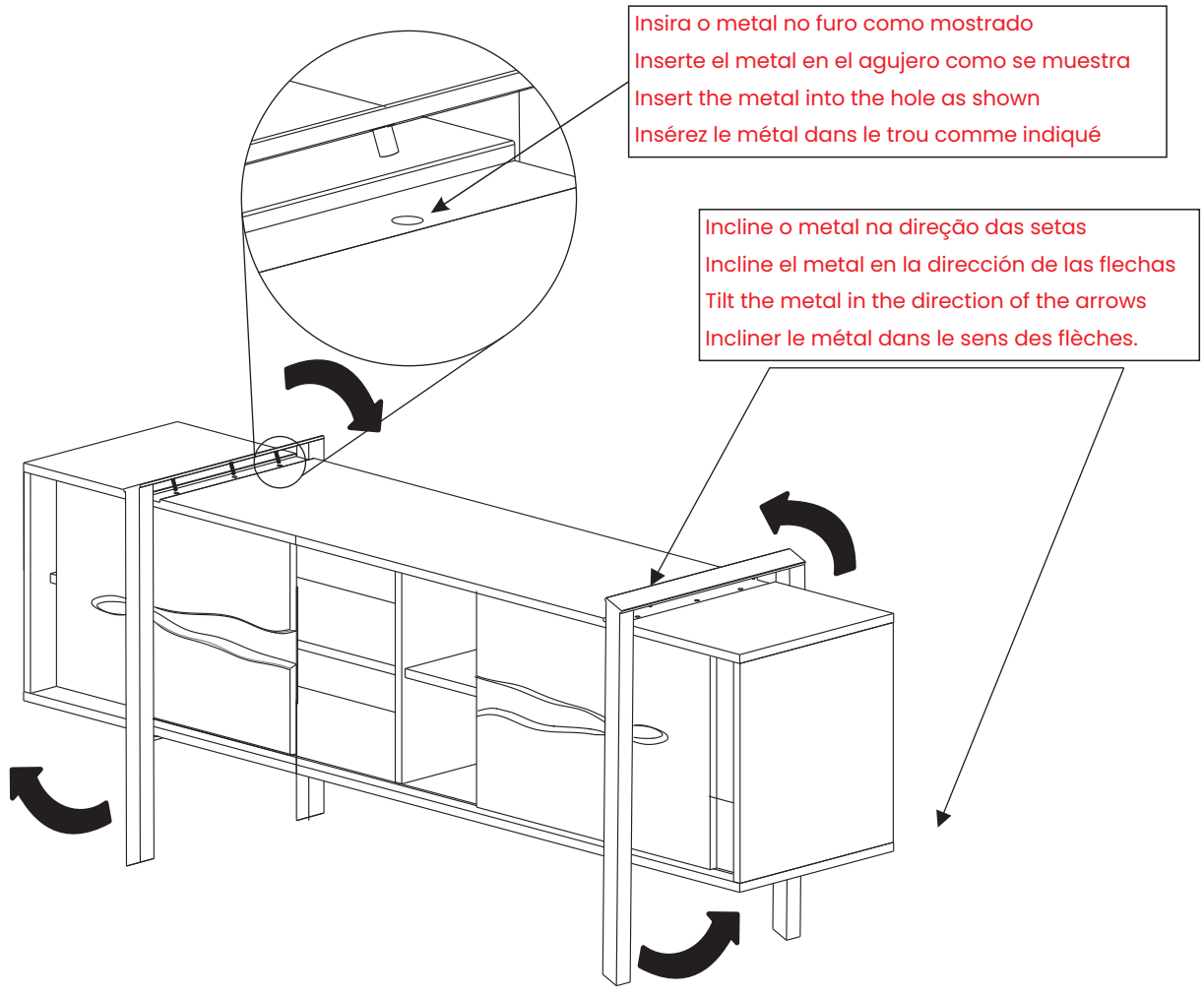

4

5

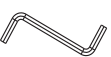

Insira o metal no furo como mostrado
 Inserte el metal en el agujero como se muestra
 Insert the metal into the hole as shown
 Insérez le métal dans le trou comme indiqué

Incline o metal na direção das setas
 Incline el metal en la dirección de las flechas
 Tilt the metal in the direction of the arrows
 Incliner le métal dans le sens des flèches.

A		1/4X20mm	06
B	 ou 	ou	01
C		1/4"x13mm	06

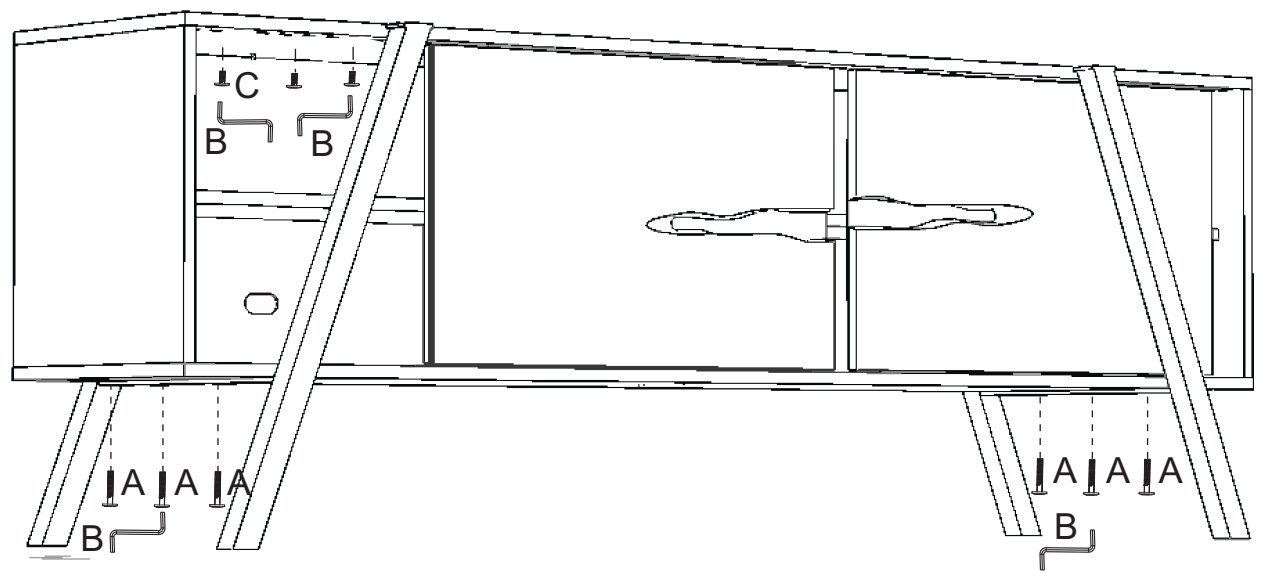

6

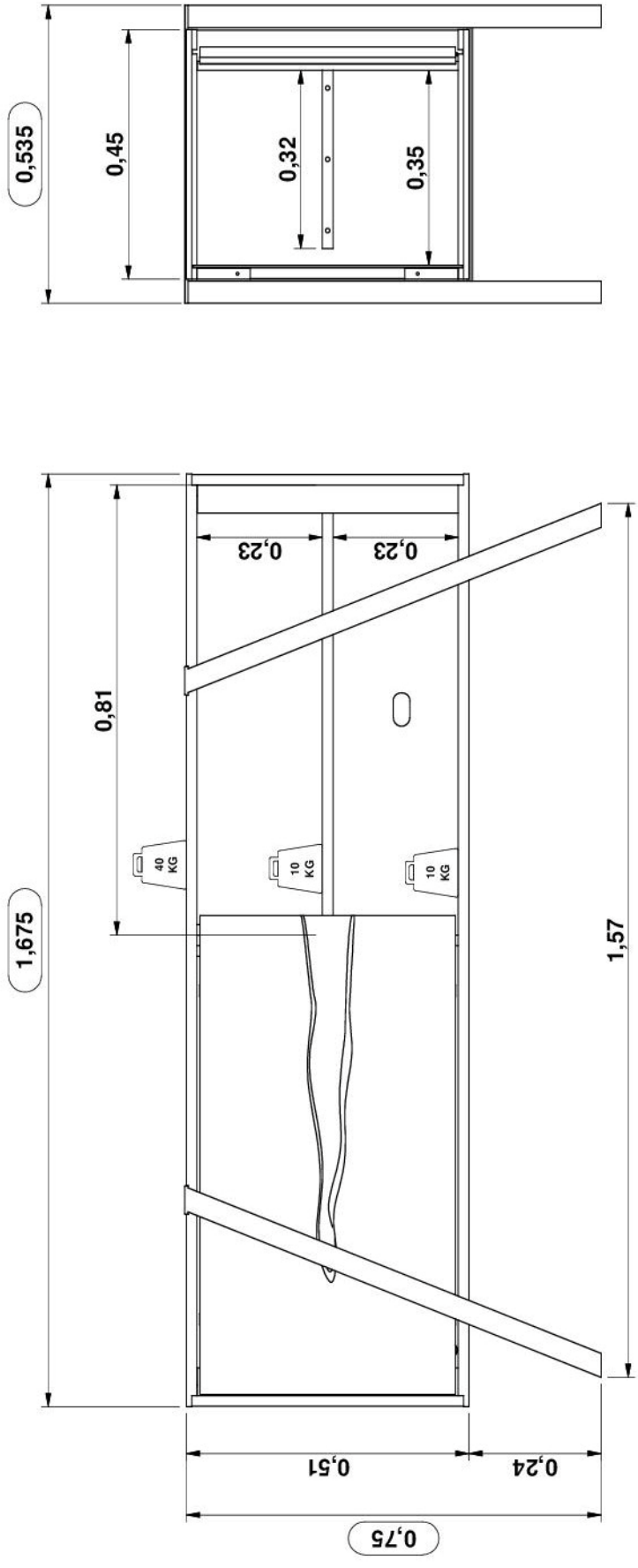

* Valor de Peso Distribuido Uniformemente

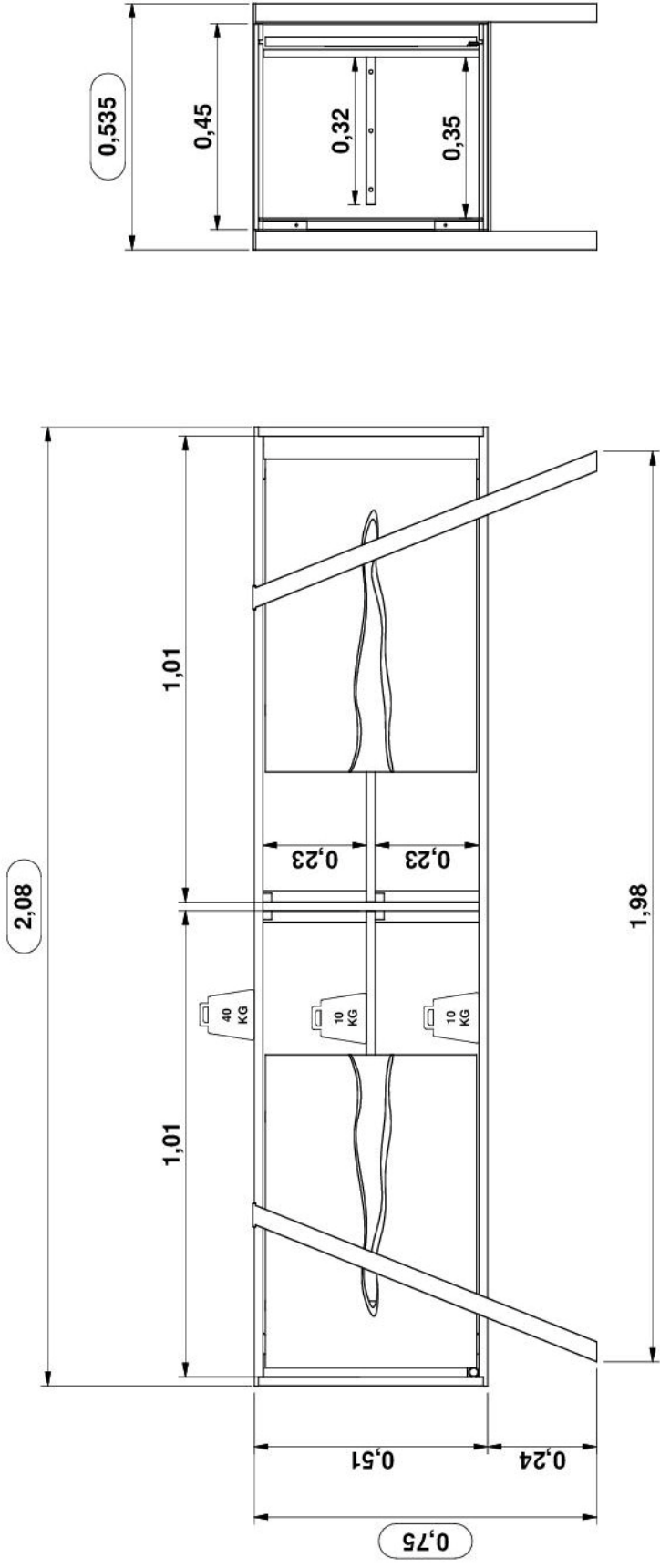

* Valor de Peso Distribuido Uniformemente